

G I A N T C R A N E

MANUAL

Revision C

GTA42S



SMART

INDUSTRIES CORP., MFG.

1626 Delaware Avenue

Des Moines, Iowa 50317 USA

(515) 265-9900 (800) 553-2442

FAX (515) 265-3148

www.smartind.com

10/27/05

GAME FUNCTIONS

SETTING THE GAME TIME

1. Press the Test Button *and* Power ON Button.
2. Wait until the power is ON, and then *release* the Test Button.
3. The flashing numbers on the display will show the GAME TIME.
4. The GAME TIME will adjust from 10 seconds to 100 seconds.
5. Push the joystick forward to increase the GAME TIME.
6. Pull the joystick backward to decrease the GAME TIME.
7. Press the CATCH Button when the desired GAME TIME is set.
8. Then, turn the machine OFF and back ON to reboot the game.

SETTING THE WIN RATE

1. Refer to the DIP Switch chart SWITCH 1 for the settings.

CREDIT SETTING

There are 2 Coin Input DIP Switch settings and 1 Dollar Bill DIP Switch setting.

1. Refer to the DIP Switch chart SWITCH 2 for the settings.

CLAW FORCE SETTINGS

The Claw Force is controlled by air pressure.

1. The STRONG Force setting should be set in the range of 3 to 5 KG.
2. The MIDDLE Force setting should be set in the range of 0.5 to 1.5 KG.
3. The WEAK Force setting should be set in the range of 0.3 to 0.5 KG.

Prize Door Test

Normal Prize Door Operation

1. When the game is turned ON, with the prize box empty, the prize door will automatically close.
2. When a prize is won, the prize sensor will detect the prize and the prize door will OPEN until the prize is removed.
3. When the prize is removed, the prize door will close.

Testing the Prize Door

1. With the power OFF, set DIP Switch SW4 #6 OFF and #7 ON.
2. Turn the power ON.
3. Press the TEST button to Open or Close the door.
4. With the prize door Open, press the TEST button to Close the door.
5. With the prize door Closed, press the TEST button to Open the door.
6. Set DIP Switch SW4 #6 OFF and #7 OFF.
7. Turn the machine OFF and back ON to reboot the game.

Forcing the Prize Door Open or Closed

1. With the power OFF, set DIP Switch SW4 #6 ON and #7 ON.
2. Turn the power ON.
3. Push the joystick forward to OPEN the prize door.
4. Pull the joystick backward to CLOSE the door.
5. The prize door limit switches are NOT recognized during this test

Sensor Timing

1. The sensors are Disabled during idle time or game operation.
2. ALL of the sensors LED's are ON.
3. The sensor is Enabled ONLY when the prize door is ready to close.
4. When the prize door is about to close, if the safety sensor detects something, the door will stop and the game will make beeping sounds.
5. Pull the joystick backward to CLOSE the door.
6. Once the safety sensors are cleared, the prize door will continue to close.

Prize Box Sensors & Motor

1. Prize Door Motor
2. Prize Door Motor Rotation Sensor
3. Prize Door Down Limit Switch
4. Prize Door Up Limit Switch
5. Prize Sensor PCB's

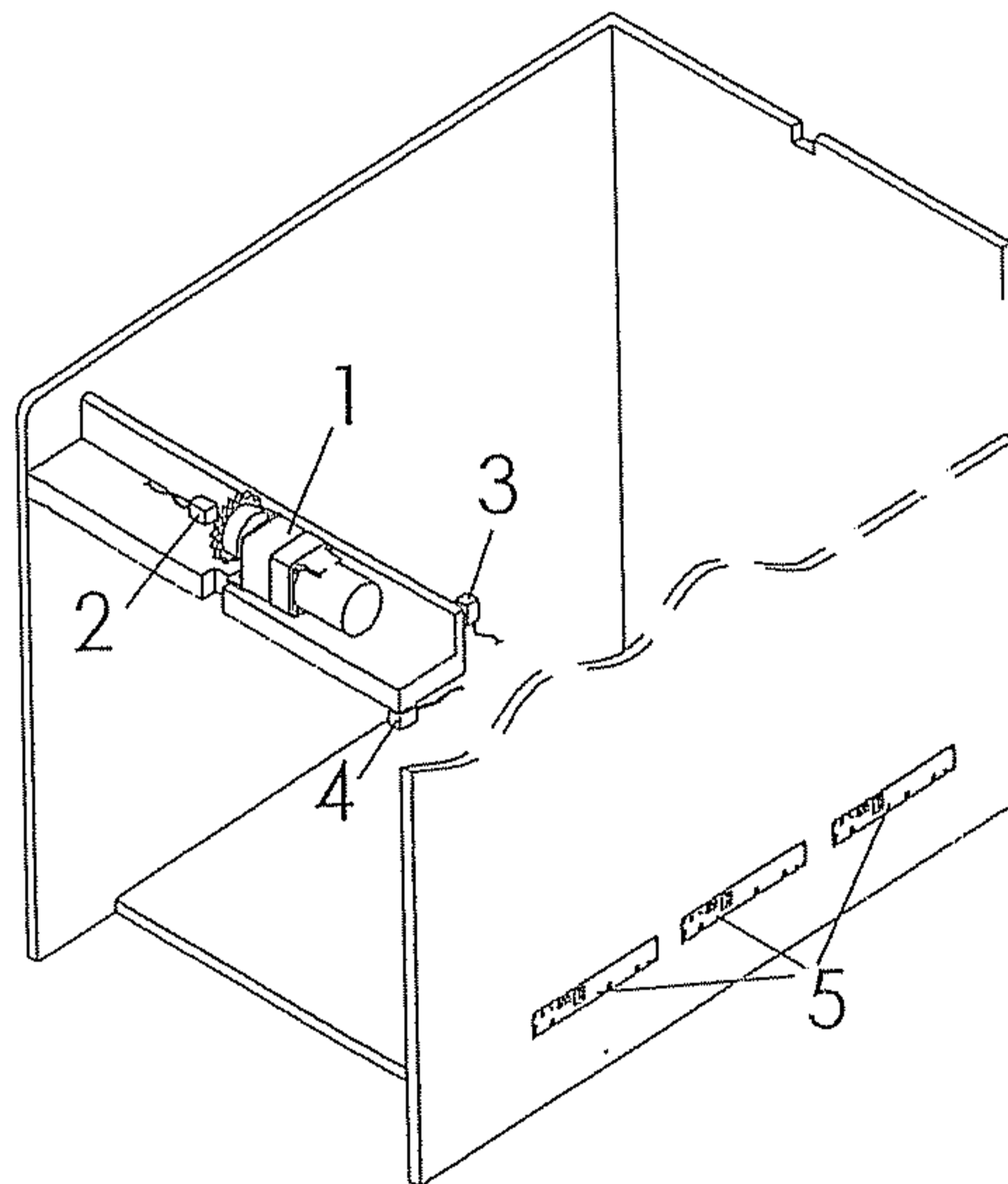

Prize Door Safety Sensor

1. Sensor Receiver Board PCB (A)
2. Sensor Receiver Board PCB (B)
3. Sensor Emitter Board PCB (A)
4. Sensor Emitter Board PCB (B)

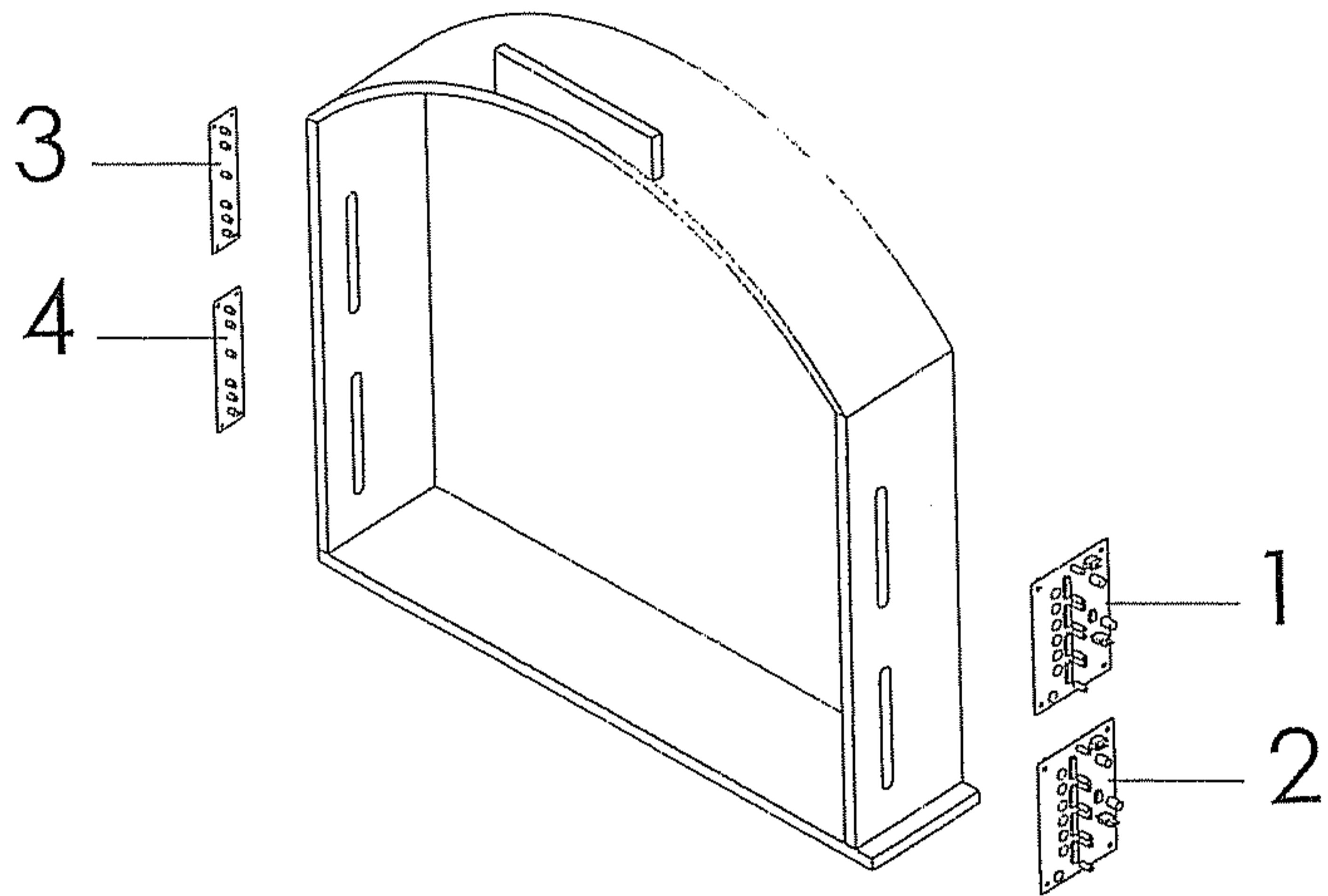

Sensor Test and Adjustment

1. With the power OFF, set DIP Switch SW4 #6 OFF and #7 ON.
2. Turn the power ON.
3. The display will show 1111.
4. On the PCB sensor boards above 1 and 2, the LED's should be OFF.
5. There should be nothing between the emitter and receiver boards.
6. If one of the LED's is ON, it may be dirty and need to be cleaned.
7. If any LED's are still ON, adjust VR on PCB's 1 and 2.
8. Turn VR clockwise to increase the "sending" signal until the LED is OFF.
9. Test the LED's to determine if they light by blocking the sensors.

Sensor ON Operation

1. The sensors are Disabled during idle time or game operation.
2. ALL of the sensors LED's are ON.
3. The sensor is Enabled ONLY when the prize door is ready to close.
4. When the prize door is about to close, if the safety sensor detects something, the door will STOP and the game will make beeping sounds.
5. Once the safety sensors are cleared, the prize door will continue to close.

The Giant Front Control Allocation

1. Main PCB
2. Motor Driver PCB
3. Music Amplifier & Sounds adjustment buttor
4. Power Supply
- 5." strong " catch force adjusting valve
- 6."middle " catch force adjusting valve
- 7." weak " catch force adjusting valve
- 8."strong" catch force electromagnetic
- 9."middle " catch force electromagnetic
- 10."weak" catch force electromagnetic
11. Gas relief (OFF) electromagnetic
12. Anti-interference PCB
13. Lighting and PCB power AC
14. Aircompressor power switch
15. Coin selector 1(COIN1)
16. Coin selector 2 (COIN2)
- 17.Bill acceptor(COIN3)
18. Coin selector 1 in meter
19. Coin selector 2 in meter
- 20.Bill acceptor in meter
21. Prize out meter
22. Future use meter
23. Test button
24. Main PCB power supply switch
25. Test button

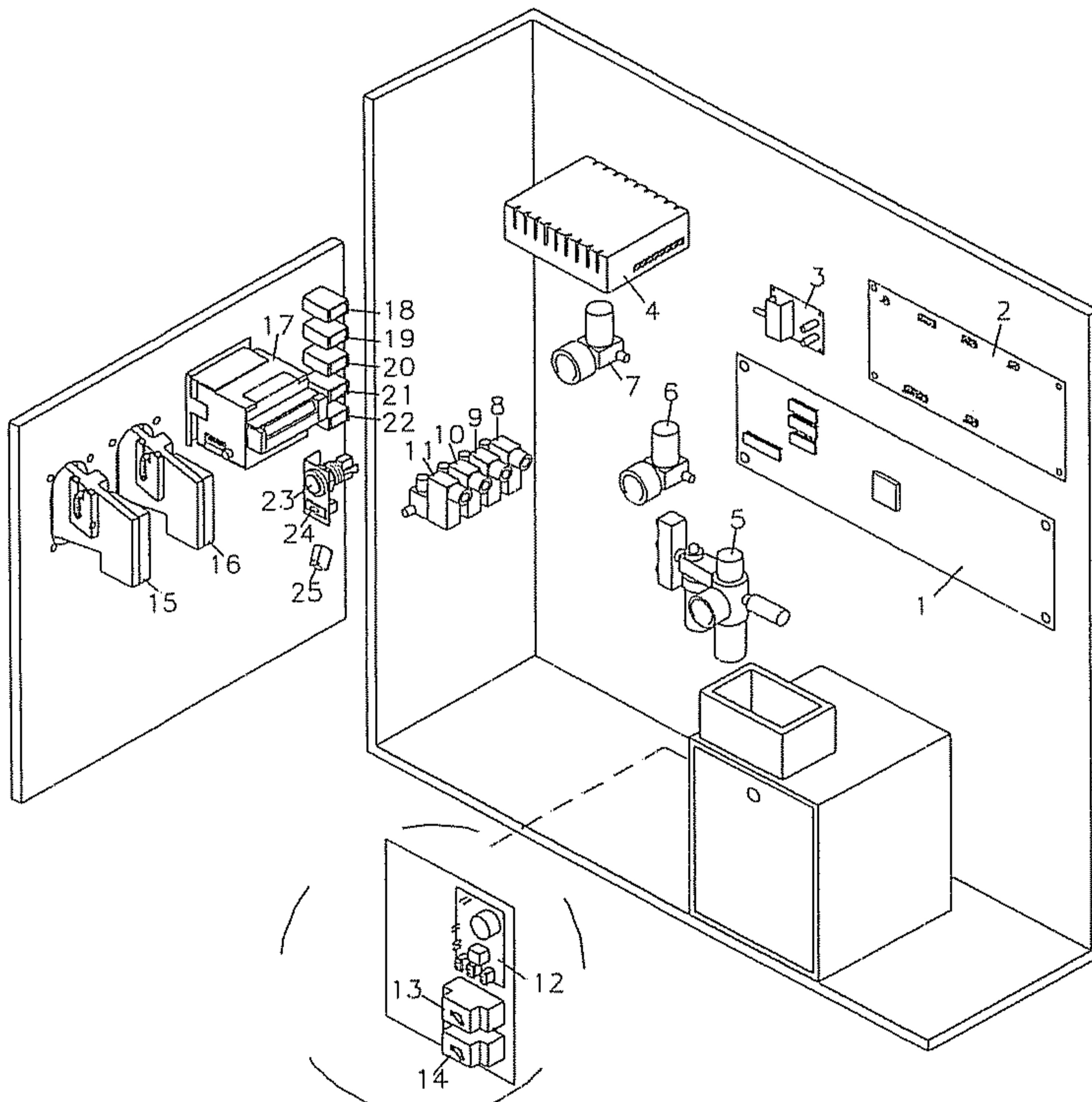

DIP SWITCH SETTINGS

Version GTA42S

SWITCH 1	1	2	3	4	5	6	7	8
To Win 1 Out Of 5 TIMES	ON	OFF	OFF	OFF	OFF	OFF	OFF	OFF
To Win 1 Out Of 10 TIMES	OFF	ON	OFF	OFF	OFF	OFF	OFF	OFF
To Win 1 Out Of 20 TIMES	OFF	OFF	ON	OFF	OFF	OFF	OFF	OFF
To Win 1 Out Of 40 TIMES	OFF	OFF	OFF	ON	OFF	OFF	OFF	OFF
To Win 1 Out Of 80 TIMES	OFF	OFF	OFF	OFF	ON	OFF	OFF	OFF
To Win 1 Out Of 100 TIMES	OFF	OFF	OFF	OFF	OFF	ON	OFF	OFF
To Win 1 Out Of 200 TIMES	OFF	OFF	OFF	OFF	OFF	OFF	ON	OFF
To Win 1 Out Of 400 TIMES	OFF	OFF	OFF	OFF	OFF	OFF	OFF	ON

SWITCH 2		1	2	3	4	5	6	7	8
COIN MECH 1	1 COIN = 1 CREDIT 1 COIN = 2 CREDITS 1 COIN = 5 CREDITS 2 COINS = 1 CREDIT	OFF ON OFF ON	OFF OFF ON ON						
COIN MECH 2	1 COIN = 1 CREDIT 1 COIN = 2 CREDITS 1 COIN = 3 CREDITS 2 COINS = 1 CREDIT			OFF ON OFF ON	OFF OFF ON ON				
BILL ACCEPTOR	1 PULSE = 1 CREDIT 1 PULSE = 2 CREDITS 1 PULSE = 5 CREDITS 1 PULSE = 10 CREDITS					OFF ON OFF ON	OFF OFF ON ON		
CENTERING	NO YES							OFF ON	
FREE PLAY	NO YES								OFF ON

SWITCH 3		1	2	3	4	5	6	7	8
1 PLAY	1 CREDIT 2 CREDITS 3 CREDITS 4 CREDITS 5 CREDITS 6 CREDITS 8 CREDITS 10 CREDITS	OFF ON OFF ON OFF ON OFF ON	OFF OFF ON ON OFF OFF ON ON	OFF OFF OFF OFF OFF ON ON ON					
NOT USED	NOT USED				OFF	OFF	OFF	OFF	OFF

DIP SWITCH SETTINGS

Version GTA42S

SWITCH 4		1	2	3	4	5	6	7	8
MID FORCE DISTANCE TO THE TOP	LONG (50 CM) MIDDLE (30 CM) SHORT (15 CM) SHORTEST (5 CM)	<u>OFF</u> ON OFF ON	<u>OFF</u> OFF ON ON						
CLAW TEST MODE SETTINGS	WEAK FORCE MEDIUM FORCE STRONG FORCE			ON OFF <u>OFF</u>	OFF ON <u>OFF</u>	<u>OFF</u> OFF ON			
FACTORY TEST	ON OFF						ON <u>OFF</u>		
GATE TEST	OPEN / CLOSE						ON	ON	
SENSOR TEST	ON OFF							ON <u>OFF</u>	
COIN MEMORY	ON OFF								<u>ON</u> OFF

MID FORCE DISTANCE TO TOP

The longer the Mid Force distance is, the shorter the time is for the strong force claw setting.

CLAW TEST MODE SETTINGS

The claw has three Air Pressure settings. See the Claw Air Pressure Adjustment page for more information.

FACTORY TEST

This setting is used as a Test Mode for the game.

GATE TEST

This Test is used to test the Prize Gate. When in this test mode, PUSH the Joystick *Forward* to OPEN the Prize Gate. PULL the Joystick *Backwards* to CLOSE the Prize Gate.

SENSOR TEST

This setting is used as a Test Mode for the Prize Sensors.

COIN MEMORY

This setting is used to SAVE game credits or CLEAR game credits after an error.

CLAW AIR PRESSURE ADJUSTMENT

CLAW TEST MODE SETTINGS

The claw has three Air Pressure settings. To set the air pressure settings, refer to the following.

STRONG FORCE

- A. Turn the power to the game OFF.
- B. Turn SW4 #3 and #4 OFF, and #5 ON.
- C. Turn the power to the game ON.
- D. The claw will close and remain closed.
- E. Adjust the Air Pressure Valve labeled STRONG FORCE to set the air pressure to the desired level.
- F. When the adjustment is complete, turn SW4 #5 OFF.
- G. Turn the power to the game OFF.

MEDIUM FORCE

- A. Turn the power to the game OFF.
- B. Turn SW4 #3 OFF, #4 ON, and #5 OFF.
- C. Turn the power to the game ON.
- D. The claw will close and remain closed.
- E. Adjust the Air Pressure Valve labeled MEDIUM FORCE to set the air pressure to the desired level.
- F. When the adjustment is complete, turn SW4 #4 OFF.
- G. Turn the power to the game OFF.

WEAK FORCE

- A. Turn the power to the game OFF.
- B. Turn SW4 #3 ON, and #4 and #5 OFF.
- C. Turn the power to the game ON.
- D. The claw will close and remain closed.
- E. Adjust the Air Pressure Valve labeled WEAK FORCE to set the air pressure to the desired level.
- F. When the adjustment is complete, turn SW4 #3 OFF.
- G. Turn the power to the game OFF.

Error Codes :

If an error code is displayed on the display, identify the code and correct the problem and then reset the game to clear the error code.

<u>Error Code</u>	<u>Problem Area</u>	<u>Solution</u>
01	IN Meter 1	Check Wiring / Replace Meter
02	IN Meter 2	Check Wiring / Replace Meter
03	IN Meter 3	Check Wiring / Replace Meter
04	OUT Meter	Check Wiring / Replace Meter
05	Coin Selector 1	Switch must be set on N/O
06	Memory Error	Replace the CPU board
07	Memory Destroyed	Reset the Game Timer
08	Sensor Error	Enter Sensor Mode to Adjust Sensor
09	Coin Selector 2	Switch must be set on N/O
10	Coin Selector 3	Switch must be set on N/O
11	Up / Down Motor	Check Fuse & U/D Limit Switches
12	Forward / Back Motor	Check Fuse & F/B Limit Switches
13	Left / Right Motor	Check Fuse & L/R Limit Switches
14	Prize Gate Motor	Door or Motor Stuck / Adjust Sensor
15	Prize Door 'Open' Sensor	Check Up Limit sensor on Prize Door
16	Prize Door 'Closed' Sensor	Check Prize Door Down Limit Sensor
17	Not Used	
18	Not Used	
19	Not Used	
20	Exit 'Safety' Sensor	Check Exit 'Safety' Sensors

The Giant Wiring Diagram(Main PCB)

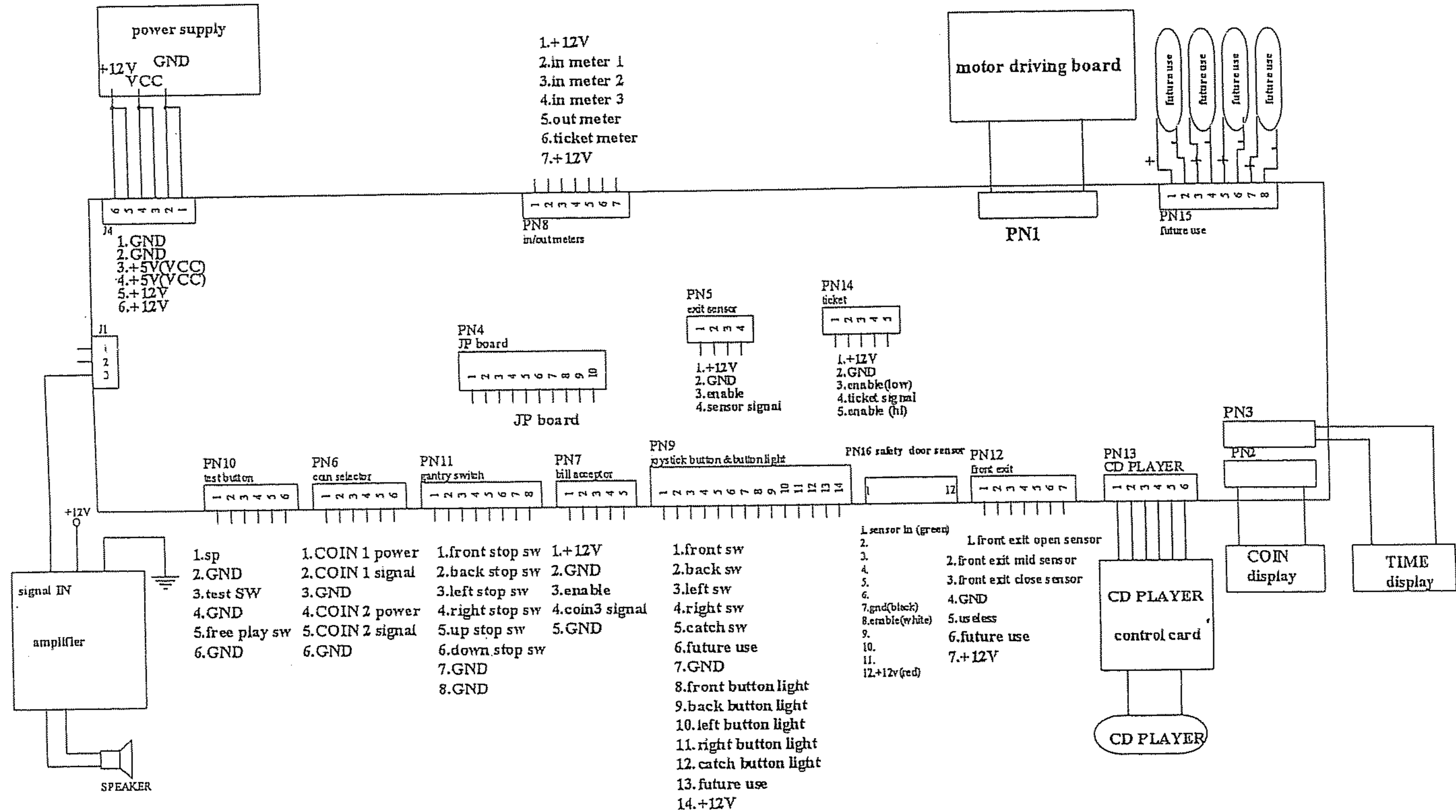

The Giant Wiring Diagram(Driver PCB)

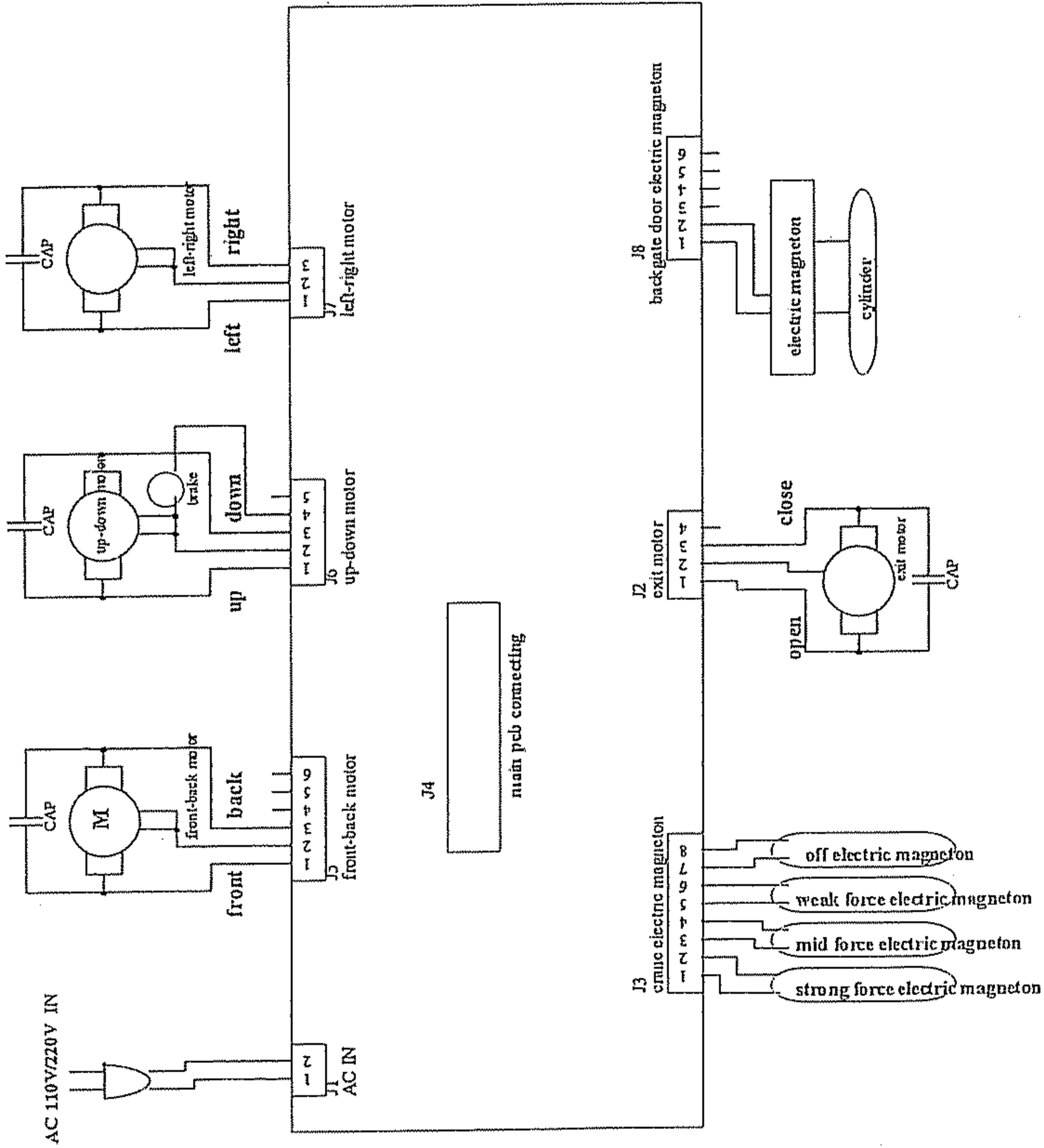

AIR COMPRESSOR

OPERATING INSTRUCTION & PARTS LIST

**DIRECT DRIVE
OIL LUBE PUMP**

IMPORTANT :

PLEASE READ CAREFULLY BEFORE STARTING OPERATION.
THE CONTENTS ARE FOR GENERAL INFORMATION OF ALL THE SIMILAR
MODELS.

Record these numbers in the space below and retain for future reference :

Power source : _____ V _____ Hz

Model No : _____

Serial No : _____

Purchased Date: _____

TABLE OF CONTENTS	PAGE
1: IMPORTANT SAFETY INSTRUCTION _____	3-4
2: GENERAL DESCRIPTION _____	5
3: ON RECEIPT INSPECTION _____	5
4: GENERAL REQUIREMENT _____	5
5: INSTALLATION _____	5-7
6: COMPRESSOR PUMP LUBRICATION _____	8
7: START UP PROCEDURE _____	8
8: MAINTENANCE CHECK LIST _____	9
9: STORAGE _____	9
10: TROUBLE SHOOTING _____	10-11

Please Note~

1 .Included screws are ~

C-5X5PCS ,D-2X5PCS ,H-1X5PCS ,H-2X5PCS ,I-1X3PCS ,J-1X2PCS ,K-1X16P

2 .While machine powers up , air compressor - OFF - current is 5A

- ON - current is 15A

3 .Input current needs to be 15A or above.

1 : IMPORTANT SAFETY INSTRUCTION



IMPROPER OPERATION OR MAINTENANCE OF THIS PRODUCT COULD RESULT IN SERIOUS INJURY AND PROPERTY DAMAGE.



PLEASE READ AND UNDERSTAND ALL INSTRUCTIONS BEFORE USING YOUR AIR COMPRESSOR.
KEEP THIS BOOKLET FOR FUTURE REFERENCE.

1-1 : RISK OF FIRE



- DO NOT SPRAY COMBUSTIBLE OR FLAMMABLE LIQUID OR PAINT WITHIN A CONFINED AREA. SPRAY AREA MUST BE WELL VENTILATED.
- DO NOT SMOKE WHILE SPRAYING OR SPRAY WHERE SPARK OR FLAME IS PRESENT.
- KEEP COMPRESSOR AT LEAST 12 ~ 18 FEET AWAY FROM SPRAYING AREA AND ALL EXPLOSIVE VAPORS.

1-2 : RISK OF ELECTRICAL SHOCK



- DISCONNECT COMPRESSOR FROM ELECTRICAL SUPPLY CIRCUIT BEFORE SERVICING.
- DO NOT EXPOSE COMPRESSOR TO RAIN OR OPERATE IN A WET AREA.
- NEVER USE THE AIR COMPRESSOR WITHOUT CONNECTION TO A PROPERLY GROUNDED OUTLET WITH THE SPECIFIED VOLTAGE AND FUSE PROTECTION.
- IMPROPER GROUNDING CAN RESULT IN ELECTRICAL SHOCK.

1-3 : RISK OF EXPLOSION



- DRAIN TANK DAILY. CONDENSED WATER WILL CAUSE RUSTING AND RISK OF TANK RUPTURE OR EXPLOSION.
- DO NOT REPAIR, MODIFY OR WELD TANK. RETURN TO AUTHORIZED SERVICE CENTER IF REPLACEMENT IS REQUIRED.
- DO NOT ADJUST REGULATOR TO RESULT IN OUTPUT PRESSURE GREATER THAN MARKED MAX. PRESSURE OF ATTACHMENT.
- PRESSURE SWITCH IS SET AT THE FACTORY FOR OPTIMUM PERFORMANCE OF YOUR PARTICULAR MODEL. NEVER BYPASS OR REMOVE PRESSURE SWITCH AS SERIOUS DAMAGE TO EQUIPMENT OR PERSONAL INJURY COULD RESULT FROM TOO HIGH OF PRESSURE.
- BEFORE STARTING COMPRESSOR, PULL SAFETY VALVE RING TO MAKE SURE THE VALVE MOVES FREELY. THE SAFETY VALVE IS FACTORY INSTALLED TO PREVENT THE AIR RECEIVER FROM DAMAGE SHOULD MALFUNCTION OCCUR IN THE PRESSURE SWITCH. IT IS FACTORY SET AT A SPECIFIC LIMIT FOR YOUR PARTICULAR MODEL, AND SHOULD NEVER BE TAMPERED WITH. ADJUSTMENT BY USER WILL AUTOMATICALLY VOID WARRANTY.

1-4 : RISK OF BURNS



- HOT SURFACE CAN CAUSE SERIOUS INJURY. NEVER TOUCH ANY EXPOSED METAL PARTS ON COMPRESSOR DURING OR IMMEDIATELY AFTER OPERATION. TOUCHING THESE AREAS MAY CAUSE SEVERE BURNS.
- DO NOT REACH AROUND PROTECTIVE SHROUNDS OR ATTEMPT MAINTENANCE UNTIL UNIT HAS BEEN ALLOWED TO COOL.

1-5 : RISK TO HEALTH

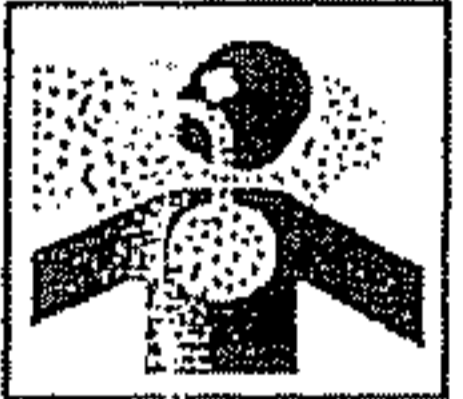

- DO NOT USE COMPRESSED AIR FOR BREATHING. WHEN SPRAYING USE RESPIRATORY PROTECTION IN A WELL VENTILATED AREA.
- COMPRESSOR AIR FROM THE UNIT MAY CONTAIN POISONOUS VAPOURS WHICH IS NOT SUITABLE FOR INHALEING AND COULD BE HARMFUL TO YOUR HEALTH.
- WORK IN AN AREA WITH GOOD VENTILATION.

1-6 : RISK FROM MOVING PARTS

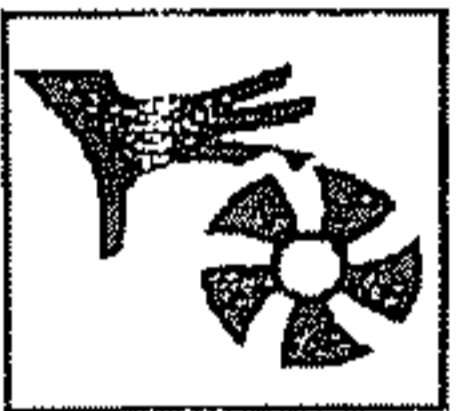

- UNIT STARTS AUTOMATICALLY. DO NOT OPERATE WITH GUARDS OR COVERS REMOVED OR BROKEN.
- ANY REPAIR REQUIRED ON THE PRODUCT SHOULD BE PERFORMED BY AUTHORIZED SERVICE CENTER PERSONNEL.
- DO NOT TOUCH MOVING PARTS.

1-7 : RISK FROM FLYING OBJECTS

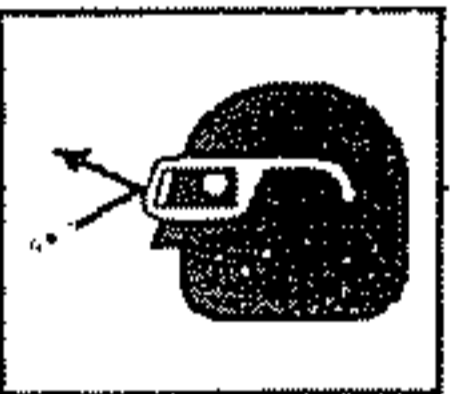

- ALWAYS WEAR ANSI Z87.1 APPROVED SAFETY GLASSES WITH SIDE SHIELDS WHEN USE THE AIR COMPRESSOR. ALWAYS WEAR PROPER SAFETY EQUIPMENT WHILE USING COMPRESSED AIR.
- DO NOT DIRECT AIR STREAM TOWARD ANY PARTS OF THE BODY OR AT OTHER PEOPLE.
- UNPLUG POWER CORD AND DRAIN ALL AIR PRESSURE FROM TANK BEFORE SERVICING AND AFTER EACH USE.

1-8 : RISK OF PROPERTY DAMAGE WHEN TRANSPORTING COMPRESSOR



- ALWAYS PLACE COMPRESSOR ON A PROTECTIVE MAT WHEN TRANSPORTING TO PROTECT AGAINST DAMAGE TO VEHICLE FROM LEAKS.
- NEVER OPERATE COMPRESSOR ON A ROOF OR OTHER ELEVATED POSITIONS.
- ALWAYS OPERATE COMPRESSOR IN A STABLE POSITION TO PREVENT ACCIDENTAL MOVEMENT OF THE UNIT.

2 : GENERAL DESCRIPTION OF AIR COMPRESSOR

The air compressor pump works with the up and down of a piston in the cylinder. During the down-stroke, ambient air is drawn in through the inlet valve, while the discharge valve remains closed. On the up-stroke of the piston, the air is forced into the compressor tank through the discharge valve and the check valve. Through this controlled action, air is forced into the tank to a preset pressure. The pressure is regulated by the pressure switch.

All tools require specific air pressure to operate properly. Consult your air tool manual for those requirements and safety instructions. There are a variety of air tools available that will operate efficiently with this air compressor. For best results, always compare the air tool requirements to your compressor output specifications. A tool that requires a lot of continuous air, such as a sander, will not operate effectively with a small tank compressor. A tool that requires little air, such as a brad nail gun, will operate with a small tank compressor very effectively. Learn your air tool power requirements, match your air tools to your compressor correctly and this compressor will perform effectively.

3 : ON RECEIPT INSPECTION

Each air compressor outfit is carefully tested and inspected before shipment. Every attempt is made to ensure safe and complete shipment of our products. It is the responsibility of the receiver of the goods to ensure the product has been shipped in full and has arrived in suitable condition. If there are any mechanical issues with your compressor, please contact us for service.

4 : GENERAL REQUIREMENT

It is your responsibility to ensure that the air compressor is properly readied for use, as well as maintained and serviced on a regular basis. Information has been included in this booklet outlining the suggested air compressor maintenance schedules and a trouble shooting guide. Be sure to follow the instructions in section 6.1 before turning your compressor on. It is important that you read this information and keep it in a safe place for future reference.

5 : INSTALLATION

5.1 : MECHANICAL

Use the compressor in a clean, dry and well ventilated area. The compressor should be located 12 - 18 inches from a wall or any other obstruction that would interfere with the air flow cooling function. Place the air compressor on a firm and level surface. The air compressor is designed with heat dissipation fins that allow for proper cooling. Keep the fins and other parts that collect dust or dirt clean. A clean compressor runs cooler and promotes longer life. Allow room for easy access to the air compressor for maintenance and service work.

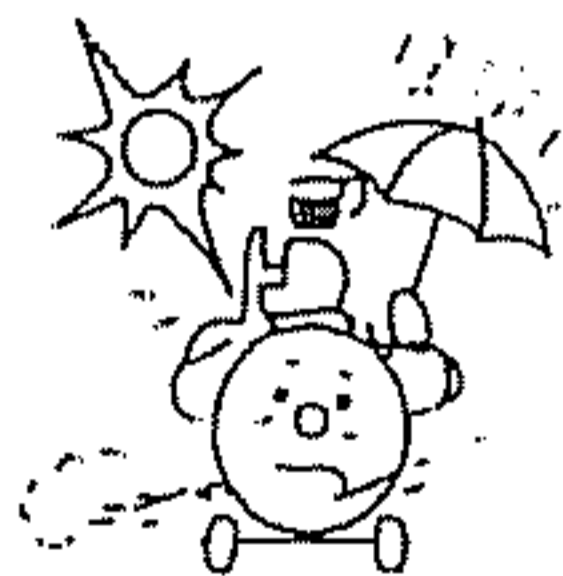

**DO NOT EXPOSE
TO RAIN**

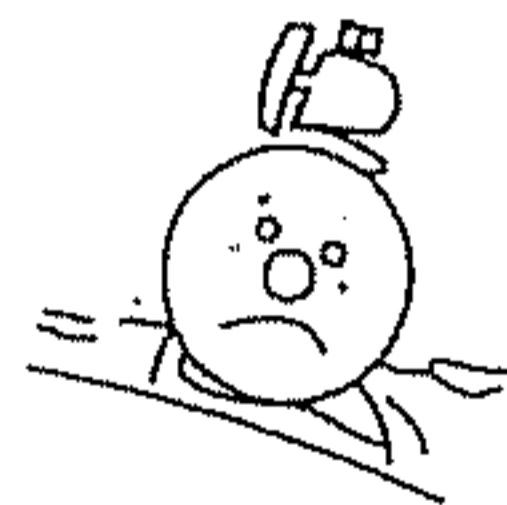

**DO NOT OPERATE
ON UNLEVEL SURFACES**



**DO NOT PLACE
IN A WET AREA**



**DO NOT PLACE IN A
CONFINED AREA WHERE
AIR FLOW IS RESTRICTED**

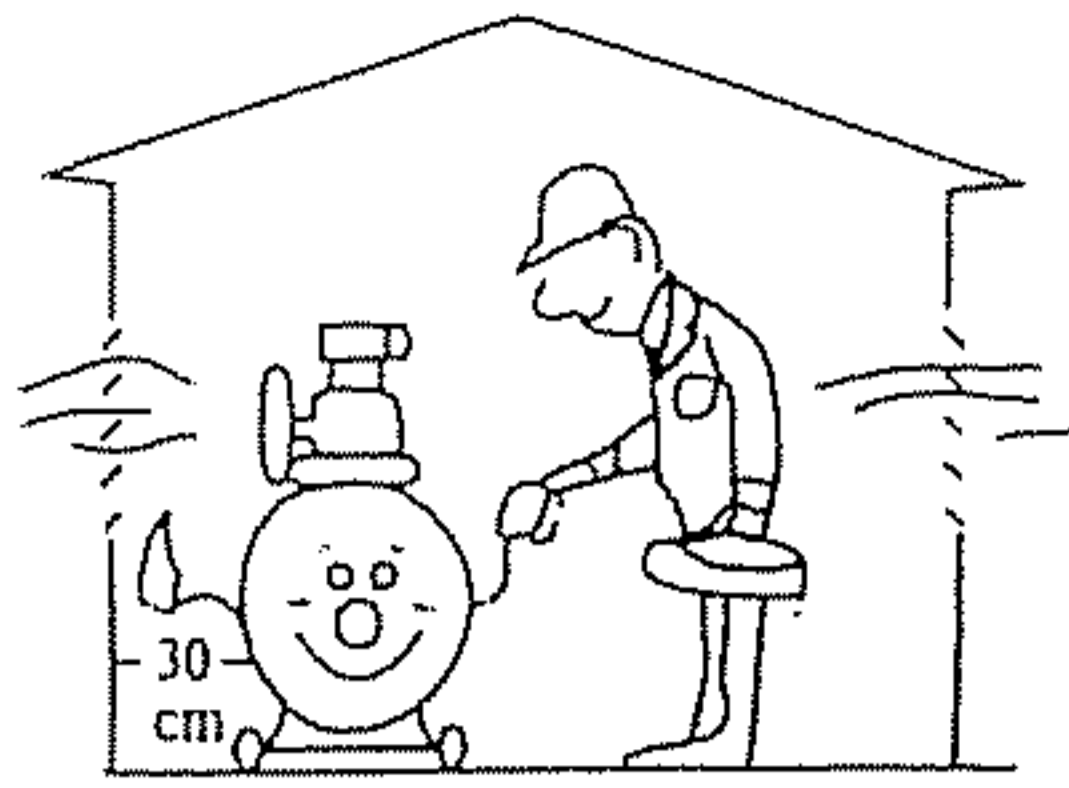

**PLACE IN A CLEAN, DRY
AND WELL VENTILATED AREA**

5.2 : ELECTRICAL

It is your responsibility to ensure that the air compressor is connected to power source in a safe and correct manner. Any electrical work should be carried out by a licensed electrician and installed in a way which meets all applicable codes and regulations.

Failure to connect the air compressor correctly to power source may result in serious personal injury or damage to the equipment.

Please note that under normal conditions, the air compressor will operate intermittently. Should it be necessary to service your air compressor, ensure the power source has been shut down. This must be done to prevent personal injury or damage to the unit.

If the supply cord is damaged it must be replaced by your dealer or all warranties and liabilities are void.

5-2-1 : MOTOR

Wiring must be completed in a manner that the full voltage nameplate $\pm 10\%$ is available at the motor terminals during startup. Use of an incorrect power source will result in premature motor failure and is not covered by this compressor or motor manufacture's warranty.

5-2-2 : RESET SWITCH

Ensure that all guards and shrouds are in place before pressing reset switch to restart the motor. If the motor shuts down because of overload, wait 10-15 minutes for the motor to cool down, then press the reset switch to restart motor. The reset switch button is located on the motor housing.

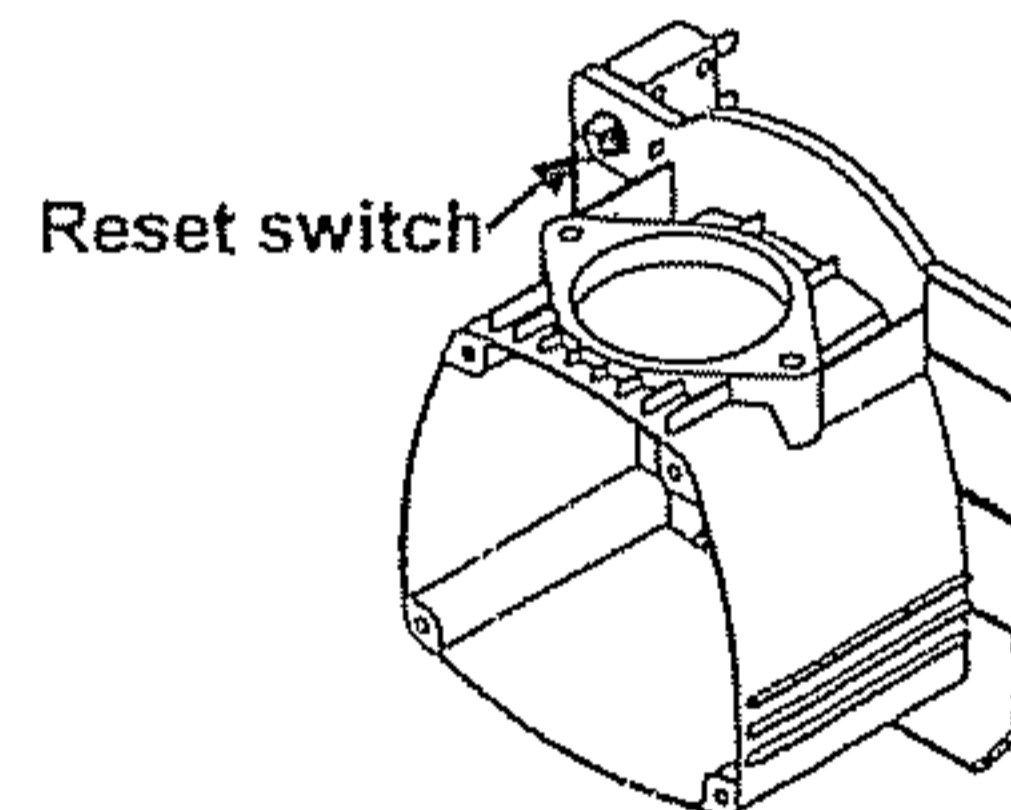

5-2-3 : PRESSURE SWITCH

The pressure switch acts as a pilot device activating the motor. The pressure switch cut in/cut out has been preset at the factory, do not tamper with the settings. Never bypass or remove this switch, as serious damage to equipment or personal injury could result from improper pressure setting. Consult your local distributor or service center if the switch malfunctions.

5-2-3-1 : This pressure switch houses the "AUTO", or "ON" switch as well as the "OFF" switch. The term "AUTO" is used because it activates the motor and allows the pump to operate until the compressor reaches the preset pressure. Once up to the preset pressure, the motor stops and switches to standby mode. After air is bleed off through use of otherwise, the pressure switch then will kick the motor back into operation so the proper air pressure will always be maintained. Thus, the compressor does have current readily available to operate the pump, and will draw on the electrical supply automatically upon need.

Always set this switch to "OFF" when the compressor is not in use and before unplugging compressor.

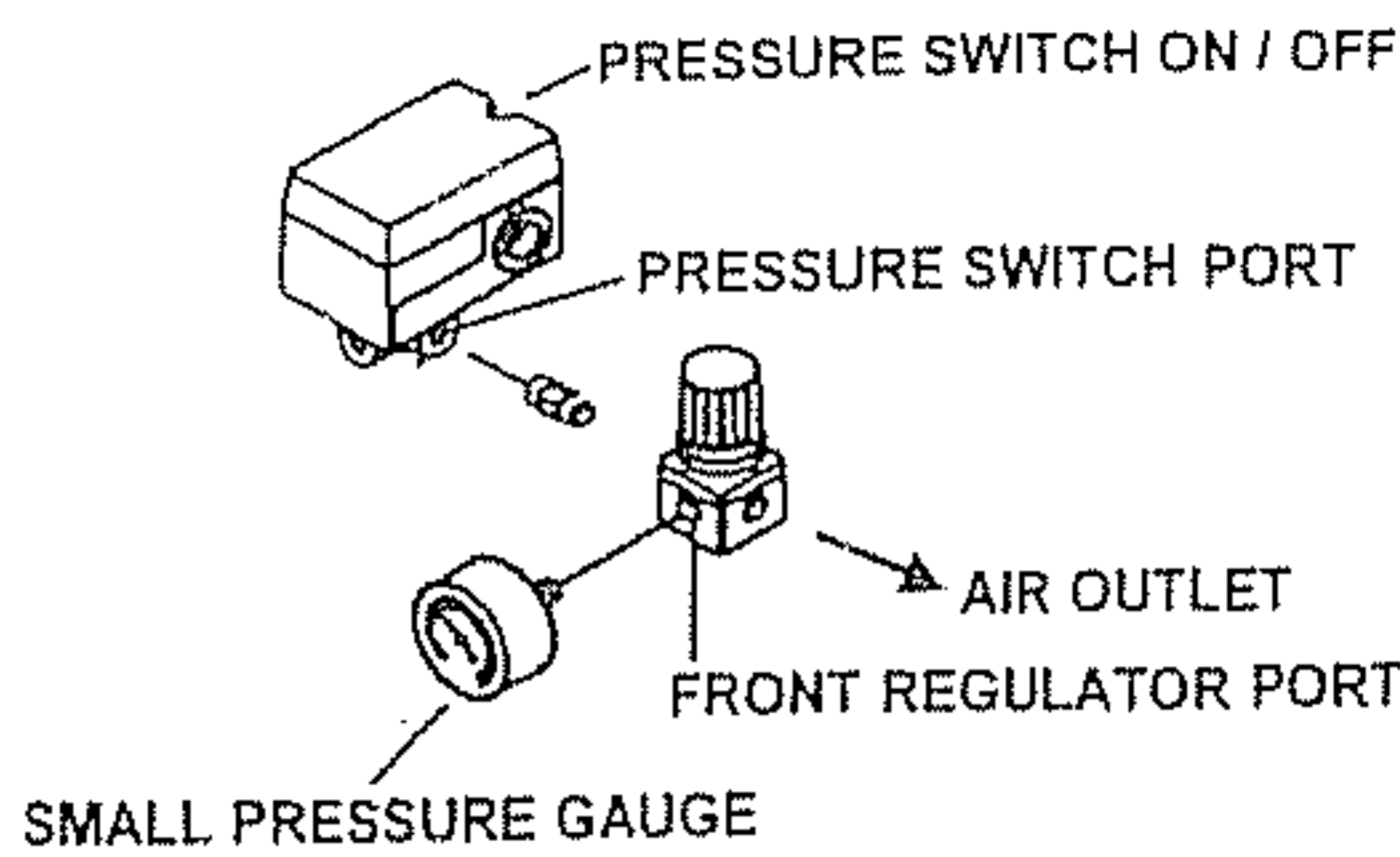

5-2-4 : AIR PRESSURE REGULATOR

The air pressure regulator enables you to adjust outlet pressure to the tool in use. Never exceed maximum working pressure of the tool. To adjust, pull the knob up and turn clockwise to increase pressure, or turn counterclockwise to decrease pressure to the tool.

5-2-5 : GROUNDING INSTRUCTIONS

Do not modify the plug that has been provided. If it does not fit the available outlet, the correct outlet should be installed by a qualified electrician. The plug must be plugged into an outlet that is properly installed and grounded in accordance with all local codes. If these grounding instructions are not completely understood, or if in doubt as to whether the compressor is properly grounded, have the installation checked by a qualified electrician.

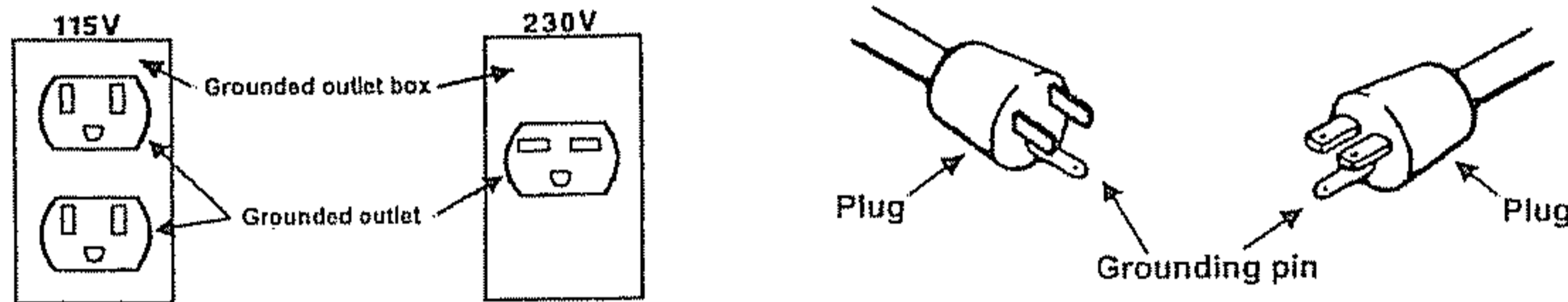

5-2-5-1 : This product is for use on a nominal 115 or 230 volt circuit. A cord with a grounding plug as shown here must be used. Make sure that the product is connected to an outlet having the same configuration as the plug. No adapter should be used with this product.
(FOR AREA OTHER THAN USA, PLEASE CHECK THE LOCAL CODE.)

5-2-6 : EXTENSION CORDS

The use of any extension cord will cause some drop in voltage and loss of power. Do not use an extension cord unless absolutely necessary. It is better to use a long air hose to reach area where work is being performed. If use of an extension cord can not be avoided, refer to the following guidelines before using.

Use only 3-wire extension cord. Make sure your extension cord is in good condition. Be sure wire gauge is sufficient.

REQUIRED MINIMUM EXTENSION CORD GAUGE				
NAMEPLATE AMPERES	EXTENSION CORD LENGTH			
	0-25 Feet	26-50 Feet	51-100 Feet	101-150 Feet
6	18	16	14	12
8	18	16	12	10
10	18	14	12	10
12	16	14	10	8
14	16	12	10	8
16	16	12	10	8
18	14	12	8	8
20	14	12	8	6
22	14	10	8	6
24	14	10	8	6
26	12	10	8	6
28	12	10	6	4
30	12	10	6	4

6 : COMPRESSOR LUBRICATION

Do not add or change oil while the compressor is in operation.
Use the recommended 30 Weight non-detergent compressor oil only.

6-1 : Oil Filling

- 6-1-1 : Remove the oil filler plug.
- 6-1-2 : Slowly pour the proper oil into the pump crankcase.
- 6-1-3 : Always keep oil level between the marks "High" and "Low" level on the oil dipstick (or on the red circle of the sight glass).

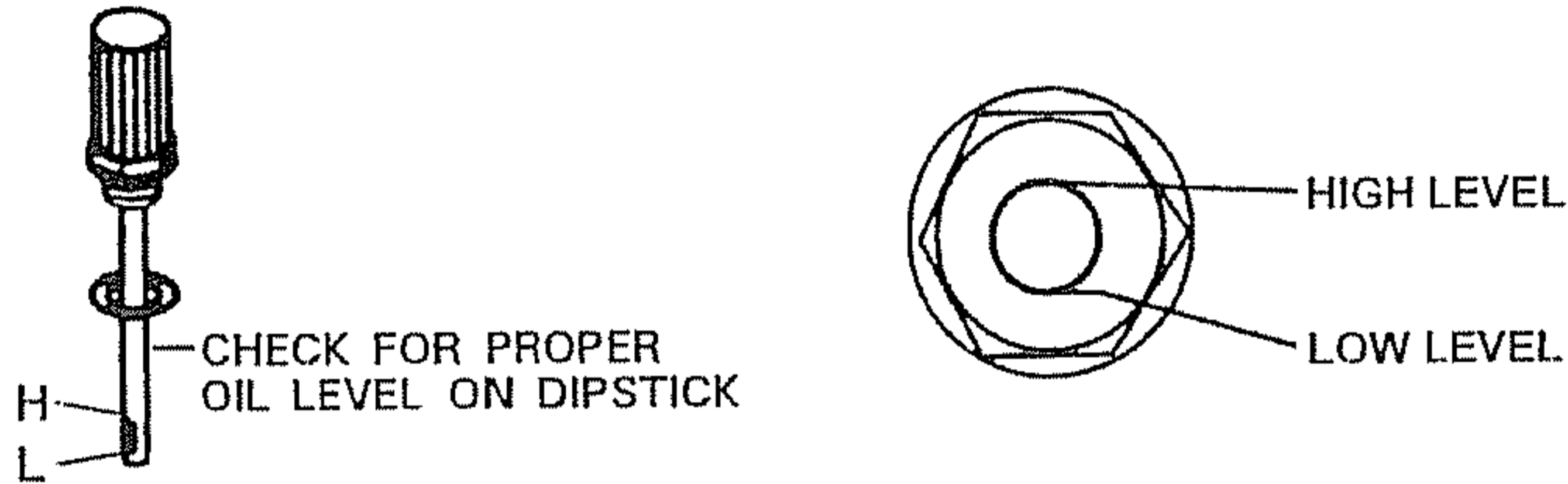

6-2 : OIL CHANGE

Change oil after the first 8 hours of compressor operation, then change oil after every 300 working hours or 3 months whichever comes first.

- 6-2-1 : Remove the oil drain plug and allow oil to drain out.
Used oil should be handled by recycle agents.
- 6-2-2 : Replace the oil drain plug. The use of a sealing compound or Teflon tape to avoid leakage is recommended.
- 6-2-3 : Refill with the recommended oil to the proper level. (See 6-1)

7 : START UP PROCEDURE

Do not attempt to operate the air compressor without first checking the oil level in the pump.
Add oil as required. Serious damage may result from running without oil.

- 7-1 : Check to see that nuts and bolts are all snug.
- 7-2 : Check that compressor is on a stable level surface.
- 7-3 : Check that air filter is clean.
- 7-4 : Do not place any materials on or against the compressor.
- 7-5 : Open the drain valve at the bottom of the tank.
- 7-6 : Turn the pressure switch lever to "AUTO".
- 7-7 : Ensure air is escaping from the drain valve. Allow the unit to operate for a minimum of twenty minutes in this no load condition.
- 7-8 : After running the compressor for twenty minutes, close the drain valve and allow the unit to reach maximum operating pressure. Ensure that the compressor shuts down at the preset maximum pressure. Notice that the head pressure is released through the unloading valve of the pressure switch.
- 7-9 : Check the air compressor and piping systems for leakages.
- 7-10 : Recheck the oil level in the crankcase. Add oil as required.
- 7-11 : Your compressor is ready for use.



Before doing any maintenance or adjustments to your air compressor, the following safety precautions should be taken.

A : DISCONNECT ELECTRICAL POWER.

B : DRAIN AIR TANK TO RELEASE AIR PRESSURE.

8 : MAINTENANCE CHECK LIST

8-1 : Daily checklist

8-1-1 : Check oil level.

8-1-2 : Drain condensation from air tank.

8-1-3 : Check for any unusual noise or vibration.

8-1-4 : Be sure all nuts and bolts are tight.

8-2 : Weekly checklist

8-2-1 : Clean air filter. Replace air filter if necessary.

8-3 : Quarterly or 300 hour checklist

8-3-1 : Change compressor oil and air filter element.

8-3-2 : Check safety valve.

8-3-3 : Check pressure switch unloads to ensure compressor head unloads whenever motor shuts down.

8-3-4 : Clean and blow off pump fins and motor.

8-3-5 : Inspect air system for leaks by applying soapy water to all joints.

9 : STORAGE :

WHEN YOU HAVE FINISHED USING THE AIR COMPRESSOR :

9-1 : Set the "AUTO/OFF" switch to "OFF" and unplug the compressor.

9-2 : Be sure to drain the water from the air tank.

9-3 : Protect the electrical cord and air hose from damage.

9-4 : Store the air compressor in a clean and dry location.

10 : TROUBLE SHOOTING :

CONDITION	CAUSE	CORRECTIVE
Compressor won't start	<ul style="list-style-type: none"> 1 : Loose electrical connection 2 : Motor overheated 	<ul style="list-style-type: none"> 1 : Check wiring connection 2 : Press reset button or wait for automatic reset
Low pressure	<ul style="list-style-type: none"> 1 : Air leak in safety valve 2 : Loose tube or fittings 3 : Restricted air filter 4 : Defective check valve 5 : Worn out rings 	<ul style="list-style-type: none"> 1 : Release safety valve manually by pulling outward on ring. If condition persists replace valve 2 : Tighten fittings 3 : Clean or replace 4 : Replace check valve 5 : Replace piston rings
Air is releasing from safety valve continuously	<ul style="list-style-type: none"> 1 : Defect pressure switch or improper adjustment 2 : Defective safety valve 	<ul style="list-style-type: none"> 1 : Check for proper adjustment and if problem persists replace pressure switch 2 : Replace safety valve
Oil discharge and excessive carbon formation or appearance of water and oil in the air lines	<ul style="list-style-type: none"> 1 : Improper oil viscosity 2 : Overfilling the crankcase with oil 3 : Restricted air intake filter 4 : Carbon on exhaust valves 5 : Worn valves 6 : Worn piston rings 7 : High ambient temperature and/or humidity 8 : High percentage of running time 	<ul style="list-style-type: none"> 1 : Replace oil with SAE 30 Weight non-detergent compressor oil 2 : Drain oil and fill to proper level 3 : Clean or replace filter 4 : Replace 5 : Replace 6 : Replace piston rings 7 : Install a moisture separator and/or oil filter 8 : Check for air leakage. If no leaks are found , you may need an additional compressor as your air demand is too much for the existing unit
Excessive noise	<ul style="list-style-type: none"> 1 : Loose valve 2 : Noisy only during start up, Check for loose belts 3 : Piping loose 4 : Unit operates on unlevel surface 5 : Improper grade of oil in crankcase 6 : Carbon or foreign material on piston 7 : Worn bearings 	<ul style="list-style-type: none"> 1 : Inspect valve 2 : Adjust for proper tension 3 : Tighten bolts and nuts as required 4 : Ensure that unit is on level surface 5 : Replace oil with SAE 30 Weight non- detergent compressor oil 6 : Clean piston. Check cylinder walls for scoring 7 : Replace main bearings

Compressor over heating	<ul style="list-style-type: none"> 1 : Undersized unit for air requirements 2 : Compressor location 3 : Air leaks in the system 4 : Restricted air filter 5 : Improper grade or level of oil 6 : Worn, damage, or carbon build up on valve 7 : Carbon build up at after-cooler tube or check valve 	<ul style="list-style-type: none"> 1 : Contact your dealer / distributor 2 : See installation section 3 : Fix leaks 4 : Clean or replace filter 5 : Replace with SAE 30 Weight non-detergent compressor oil 6 : Clean, repair or replace valves 7 : Clean or replace
Pressure switch unloading valve does not function or leak air when unit is operating or not operating	<ul style="list-style-type: none"> 1 : Pressure switch unloading valve may be dirty or faulty 2 : Check valve may be dirty or faulty 	<ul style="list-style-type: none"> 1 : Clean, or replace unloading valve 2 : Clean, or replace check valve
Water in air tank	<ul style="list-style-type: none"> 1 : Condensation in the air tank during normal usage 	<ul style="list-style-type: none"> 1 : Drain daily or install an automatic drain
Oil leaks or appearance of oil on the compressor	<ul style="list-style-type: none"> 1 : Spillage of oil when filling 2 : Overfilling the crankcase 3 : Improper grade of oil 4 : Leak at oil filler plug 5 : Oil leak at gasket, cylinder or crankcase 6 : Loose plug 7 : Loose side or end plate 8 : Oil seal leak 	<ul style="list-style-type: none"> 1 : Wipe unit clean 2 : Drain oil and fill to proper level 3 : Replace with proper SAE 30 non-detergent compressor oil 4 : Tighten or replace oil filler plug 5 : Replace gaskets as required 6 : Tighten plug 7 : Tighten plates 8 : Replace oil seal

Gantry Cable Support Bracket Mounting

When connecting gantry cable support brackets, note the position of the cable support brackets. This is the position the brackets are in during shipment of the crane.

Back view of the gantry unit. Picture #1

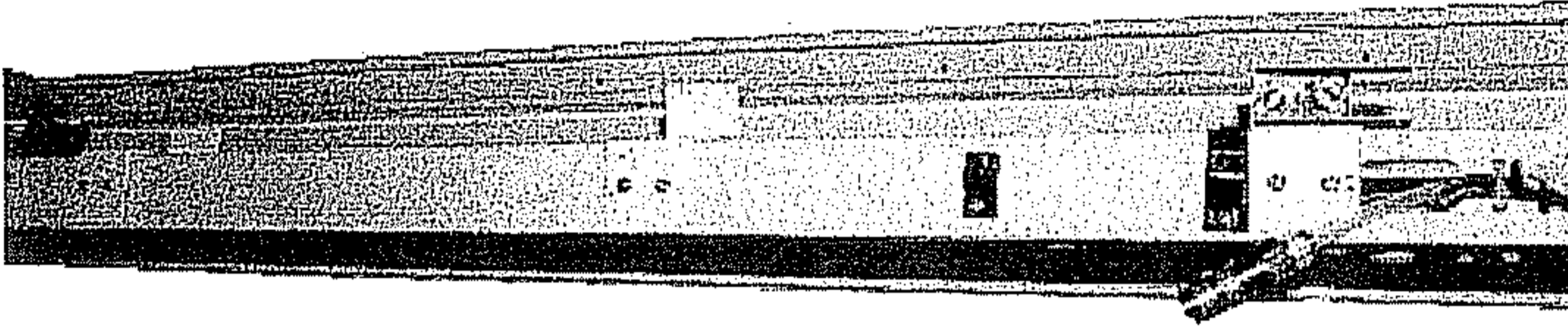

BEFORE

Remove the 2 screws from each of the 3 brackets shown in Picture #1 above.

Reverse the 3 brackets and replace the screws as shown in Picture #2 below.

Back view of the gantry unit. Picture #2

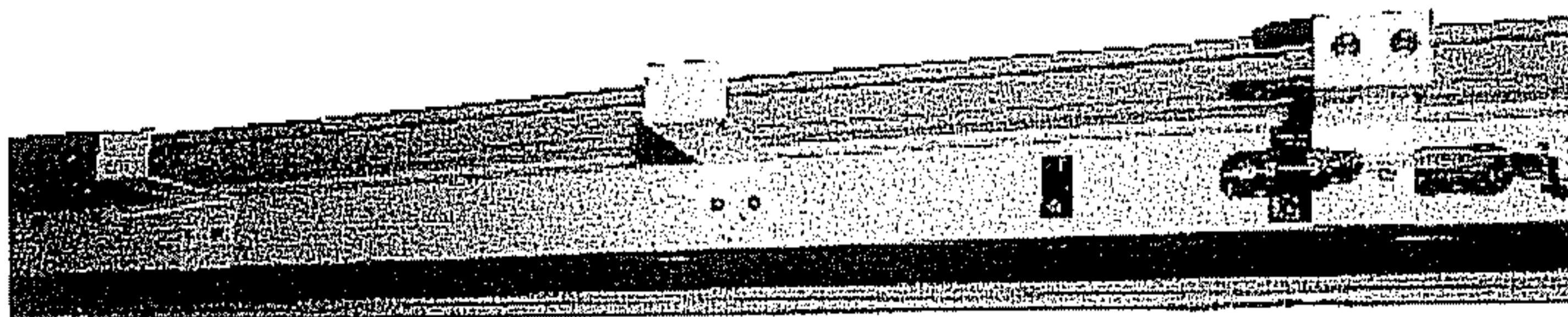

AFTER

Crane Head Air Hose Connection

When connecting the air hose from the claw, note the position of the cable harness and the cable support brackets. Note the position of the air hose and the wire harness.

Back view of the gantry unit. Picture #1

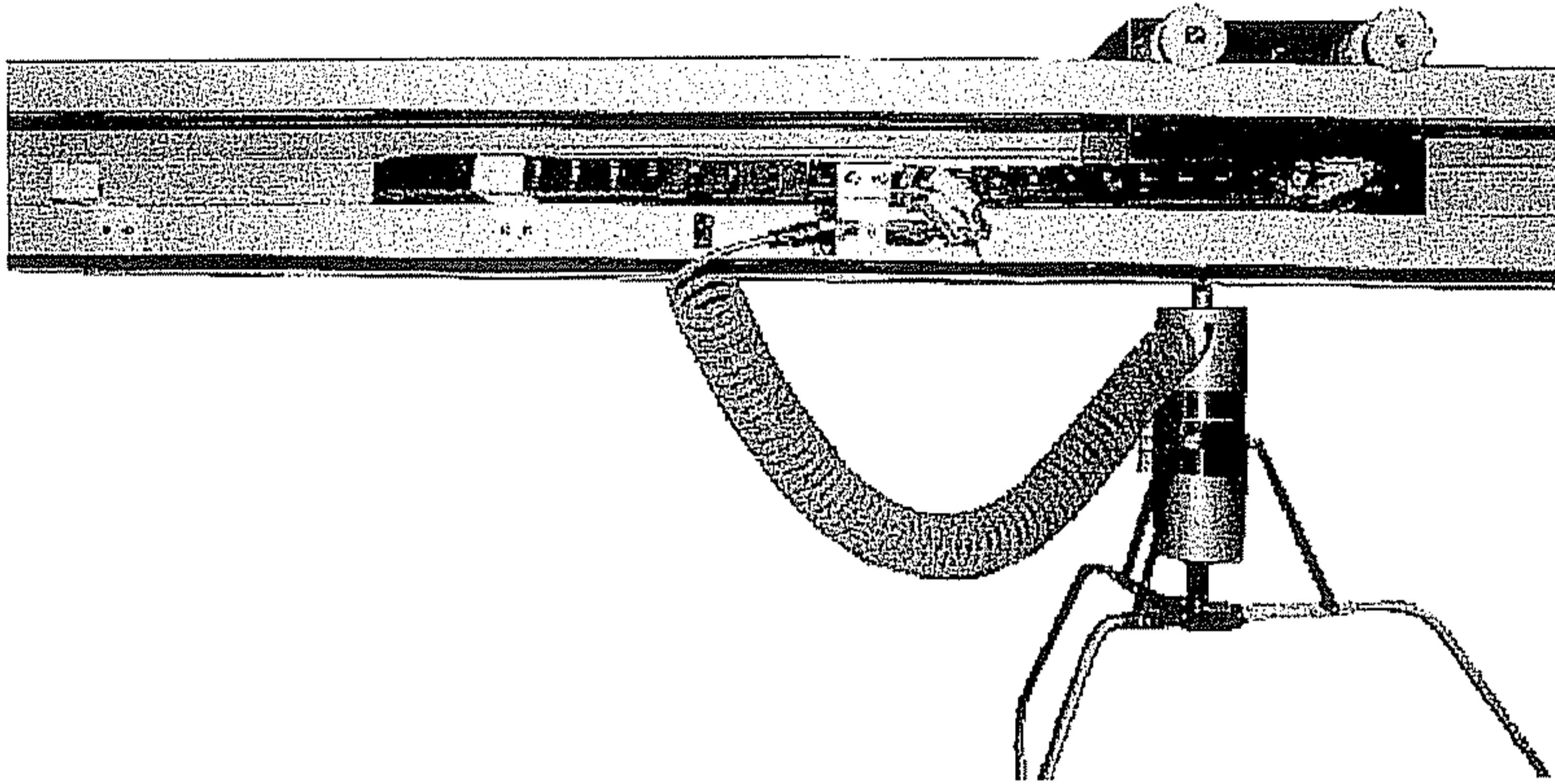

Back view of the gantry unit. Picture #2

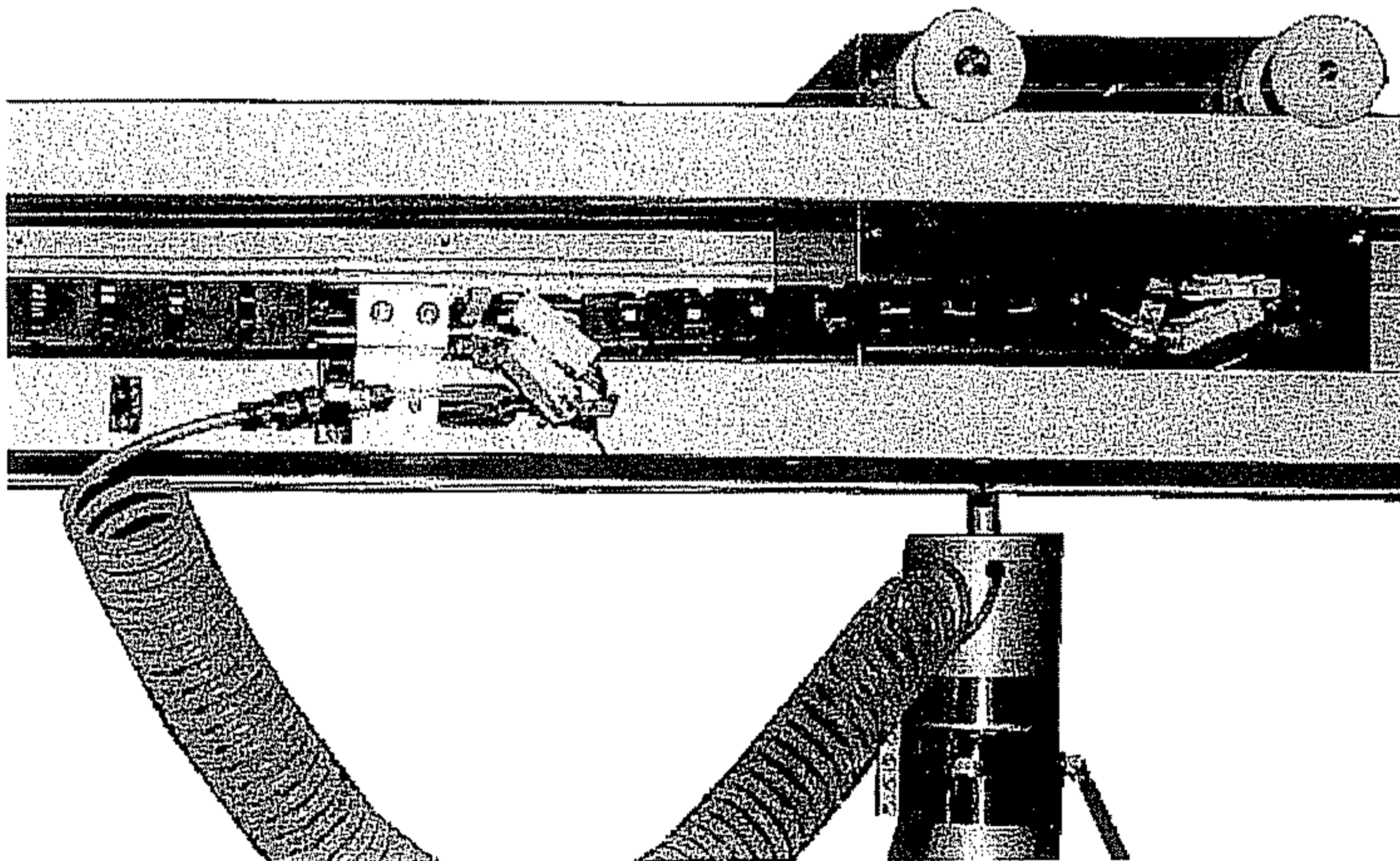

Steps for manual

Tips

- Unpack and lay parts out on the floor before assembly to insure all parts are there.
 - Panel parts slide together with grooves, note how the arrows go in the drawings.
 - Easiest for two people to put together panels. One to act as a brace and the other to push the pieces together. Best to do this with pieces flat on the floor.
 - Floor should be level where Giant Crane is to be installed.
-
- ❖ Parts list including part numbers and names
 - Screws
 - List by size and name with outline drawing
 - ❖ Step by step instructions for assembly
 - Front Panel
 - Side panels
 - Back Panel
 - Top supports
 - Floor supports
 - Top Panels
 - Floor Panels- Add left then right side will be added later
 - Frame supports
 - Front consul
 - Prize box
 - Wiring
 - Compressor
 - Gantry
 - Right side Floor panel
 - Test and add plush

Steps to assemble:

Front panel

1. Put 2 and 3 together and affix 5 to right edge.
2. Slide on 1 and add 6 to bottom of 1
3. Assemble 7 and 8 and use screw L-1 to right side
4. Add 4 to left side.

Should resemble drawing for the Front Panel.

Side panels

1. Assemble 10 and 11
2. Connect 9 (see arrow directions) should look like drawing).
3. Assemble 13 and 14
4. Connect 12 (see arrow directions) should look like drawing).

Back Panel

1. Attach 17 to 15 with screw L-1

2. Attach 18 to 16 with screw L-1
3. Assemble 15 and 16

You should now have four panels a front, a back and two sides with corner supports on the front and back panels.

- Attach the four panels together to form a square as pictured.
- Now attach part 19 to the bottom of the front panel and the back panel as shown using brackets 120 and the H-1 screws
- Now attach part 20 to the top of the front and back panels using the 120 bracket and H-1 screws as shown in the illustration.

You should now be ready to attach the top two panels number 21 and 22. Note how the corners are cut in the illustration. One is for the left side and one is for the right.

You may also want to put the left floor panel in at this time and leave the right panel out until after you have added the Gantry and Crane.

Gantry support

1. Measure the distance between the right and left sides at points A, B and C. They should be the same. This will insure that the Gantry moves smoothly along the rails you are about to install.
2. Install the "L" brackets with the "Stops" to the rails as shown in illustration "E" using A-7 screws.
3. Install parts 23-2 and 23-1 using the brackets #23-2B and A-7 screws. Make sure the "A" label is to the front door and the "B" label is close to the back wall. You may want to use a level to make sure that the rails are at the same height front to back.
4. Use the "L" brackets for the center support of each rail.
5. You may want to wait to mount the Gantry with the Crane until after the electrical wiring has been

Consol and Prize Box

1. Attach the consol to the front panel as shown in drawing "H" using A-10 screws and D-3 washers.
2. Attach the floor of the Prize Box using 6 A-10 screws and D-3 washers. You will need to turn the Prize box so you have access to the bottom.
3. If the moving door to the Prize Box is not attached you will need to turn the Prize Box on it's back and feed the moving door into the tracks so it will slide easily. You will then have to connect the chain so the door will go up and down.
4. Move the Prize Box into the Giant Crane via the walk-in door and attach the Prize Box to the front panel using A-10 screws and D-3 washers.

Wiring

Back of wiring tubing has two-sided tape to attach it to the front panel and the left panel of the Giant Crane. It may be easier to snap the three-sided cover off before attaching the back to the Giant Crane.

1. Attach the back of the wire protector to the Giant Crane as shown in drawing “White fix tube & related positions”
 - Part L 4: 13.5 cm = 5.31 inches
 - Part L 3: 47.5 cm = 18.7 inches
 - Part L 2: 49 cm = 19.29 in
 - Part L 5: 80 cm = 35.04 in
 - Part L 1: 100 cm = 39.37 in
2. Lay out wiring as shown on both Wiring Configuration drawings.
3. Snap the covers back onto the wiring protectors.
4. Attach florescent lights to Top panels as shown in drawing.
5. Attach wires and air hose from Gantry as shown in drawing A and A’
6. Connect left top panel lamp as shown in drawing C (Wire with shorter end)
7. Connect right top panel lamp as shown in drawing D (Wire with longer end)
8. Attach the cover for the air compressor using A-9 screws and D-3 washers. There is an access door, which is used to install and service the air compressor.
9. Attach ground wire as shown in Grounding illustration.
10. Check oil in air compressor and follow other instructions in the Air Compressor Manual before starting the first time.
11. After initial start up, install the air compressor and connect the air hoses. Set air pressure as described in the Air Compressor Manual.
12. Mount Gantry and connect wires and air hose as shown in drawings. Make sure the wire is going between Gantry and Rail not over rail.
13. Make sure air hoses are connected as shown in Exit back door components description sheet.
14. Set DIP switches and test as shown in accompanying manual.
15. If all tests pass, install the right bottom floor panel and fill Giant Crane with plush.

Giant Crane Parts List

	A	B	C
1	Part Number	Description	Quantity
2	2	Front panel upper window	1
3	3	Front panel lower window	1
4	4	Front left corner support	1
5	5	Front middle support	1
6	6	Front upper door support	1
7	7	Front right door support	1
8	8	Front right corner support	1
9	10	Left front window	1
10	11	Left rear window	1
11	13	Right front window	1
12	14	Right rear window	1
13	15	Back left window	1
14	16	Back right window	1
15	17	Rear left corner support	1
16	18	Right rear corner support	1
17	19	Floor brace	1
18	20	Top brace	1
19	21	Right top panel-note notch	1
20	22	Left top panel-note notch	1
21	56	End support for Gantry rail	4
22	57	L bracket for front Gantry stop	2
23	58	L bracket for rear gantry stop	2
24	59	Gantry stops	4
25	60	23-2B L bracket for center Gantry support	2
26	61	23-2 Left Gantry support rail	1
27	62	23-1 Right Gantry support rail	1
28	63	Front gantry cover piece	1
29	64	Bottom protector for Claw motor	1
30	65	1 Front panel marque	1
31	66	9/12 Left/Right side marque	2
32	67	Consol Control panel plate	1
33	68	Consol Prize box Plastic liner	1
34	69	Consol cover	1
35	71	Consol door hinge??	1
36	72	Consol Prize box entry frame	1
37	73	Prize box frame	1
38	74	Consol Joystick	1
39	75	Consol Crane lowering button	1
40	76	Consol LED lights	2
41	77	Consol Coin selector	2
42	78	consol Bill acceptor dba	1
43	79	consol door lock	1
44	80	Consol Speaker	2
45	81	consol Power supply	1
46	82	Consol Music Amplifer & sound adjustment button	1
47	83	Consol Motor driver PCB	1
48	84	Consol Main PCB power supply switch	1
49	85	Consol Catch force electromagnetic	4
50	86	Consol "Weak" catch force adjusting valve	1
51	87	Consol "Middle" catch force adjusting valve	1

Giant Crane Parts List

	A	B	C
1	Part Number	Description	Quantity
52	88	Consol " Strong" catch force adjusting valve	1
53	89	Consol Pwer breakers	2
54	90	Consol anti-interference PCB	1
55	91	Consol compressor power outlet	1
56	92	Consol meter	5
57	93	Consol Test button	1
58	94	Consol Main PCB power supply switch	1
59	95	Consol Test button	1
60	96	Consol Prize box frame Sensor Send PCB	2
61	97	Consol Prize box frame Sensor Receive PCB	2
62	98	Prize box floor sensors	3
63	99	Prize box electrical wire cover	1
64	101	Prize box left side molding	1
65	102	Prize box right side molding	1
66	103	Prize box chain gear	1
67	104	Prize box Motor mounting bracket	1
68	105	Prize box door motor	1
69	106	Prize box Mounting bracket bottom spacer	1
70	107	Prize box door motor thing right side	1
71	108	Prize box door Motor rotation sensor	1
72	109	Prize exit door "Close" sensor	1
73	110	Prize exit door "Open" sensor	1
74	111	Prize box door chain	1
75	112	Prize box door cover (grage door)	2
76	113	Prize Box door guide	1
77	114	Floescent light fixture	6
78	115	Front florescent bulb	6
79	116	Rear florescent bulb	6
80	117	Air Compressor	1
81	118	Air Compressor Dog House with service door	1
82	119	Top/FloorSupport brackets	1
83	120	Front top support bracket	1
84	124	Rear Prize door bracket	1
85	125	Rear prize box air exchange cylinder	1
86	126	Rear prize box air connection piece	1
87	127	Rear prize box Air cylinder bracket	2
88	128	Rear prize box cover	1
89	129	Walk-in door lock	1
90	130	Walk-in door handle	1
91	131	Walk-in door hinge	2
92	132	Consol EMI filter	1
93	133	Consol EMI filter	1
94	134	Consol Phone jack outlet	1
95	L 1	2 Piece wire protector 39.37 in	3
96	L 2	2 Piece wire protector 19.29 in	1
97	L 3	2 Piece wire protector 18.7in	1
98	L 4	2 Piece wire protector 5.31in	1
99	L 5	2 Piece wire protector 35.04 in	1

Part Number	Description	Quantity	Size
A-10	XXX Phillips Head Screw		
A-7	XXX Phillips Head Screw		
A-9	XXX Phillips Head Screw		
D-2	XXX Washer		
D-3	XXX Washer		
H-1	XXX Phillips Head screw		
J-1	1/4" X 57L Phillips Head screw		
I-1	XXX Non-Phillips Head Screw		
	L bracket for center Gantry support	2	
23-2(B)	End support for Gantry rail	4	
C-5	XXX Acorn nut_ fit carrage bolt	82	
	Carrage bolt	67	2.25"
	Rd head metal screw Hex head	9	2.5"
	Flat head metal screw	4	2.25"
	Flat washer	21	5/16"
	Rd head hex metal screw	12	1.5"
	Rd head hex metal screw	3	1"
	Rd head hex metal screw	9	5/8"
	flat washer	70	.25"
	Self-tapping sheet metal screw Rd head hex	5	2.5"
	Self-tapping sheet metal screw flat head hex	16	5/8"
	Rd head hex wood screw	15	1/2"
	Rd head hex wood screw	15	3/4"
M5	Brass metal screw rd hd hex with locking washer large	10	3/8"
M5	Brass metal screw rd hd hex with locking washer Medium	16	3/8"
M5	Brass metal screw rd hd hex with locking washer small	10	3/8"
	Twist ties	20	5.5"
Aux bag	3 keys		
	1 Phillips head screw driver		
	16 O-Rings		
	2 Self adhesive back plastic wire harness holders with a wire tie slot		
	15 c4 wire connectors-may be for ground wires		
	6 rubber wire harness protectors		

Part Number	Description	Quantity	Size
A-10	XXX Phillips Head Screw		
A-7	XXX Phillips Head Screw		
A-9	XXX Phillips Head Screw		
D-2	XXX Washer		
D-3	XXX Washer		
H-1	XXX Phillips Head screw		
J-1	1/4" X 57L Phillips Head screw		
I-1	XXX Non-Phillips Head Screw		
	L bracket for center Gantry support	2	
23-2(B)	End support for Gantry rail	4	
C-5	XXX Acorn nut		

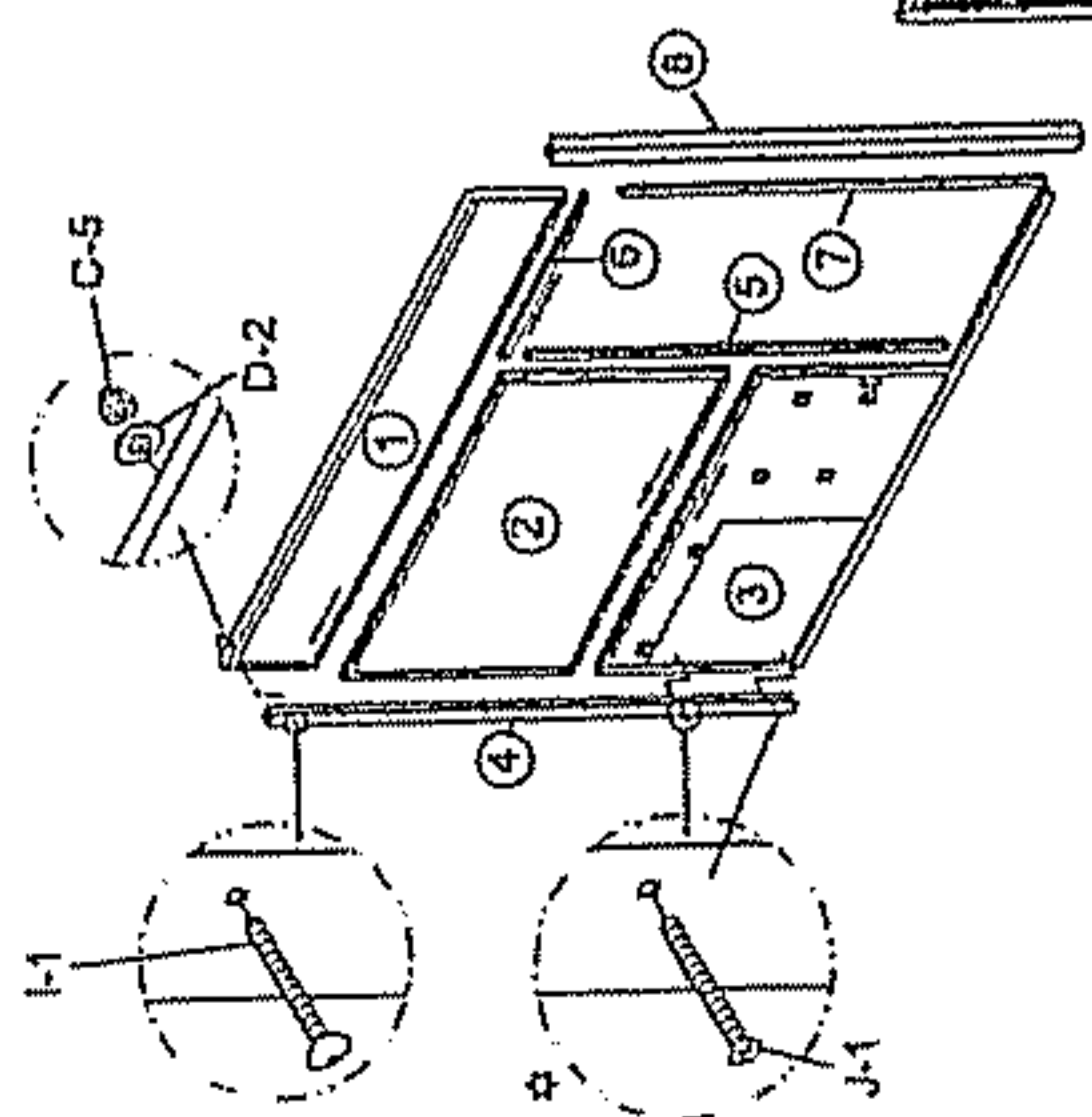

Assembly step:
 a. First put 2 and 3 together, and fix 5. Then assemble 1, finally assemble 6.
 b. Assemble 7 and 8 and fix with screw J-1
 c. Note Marked ☆ need to fix with J-1 (1/4" X 57L) screw

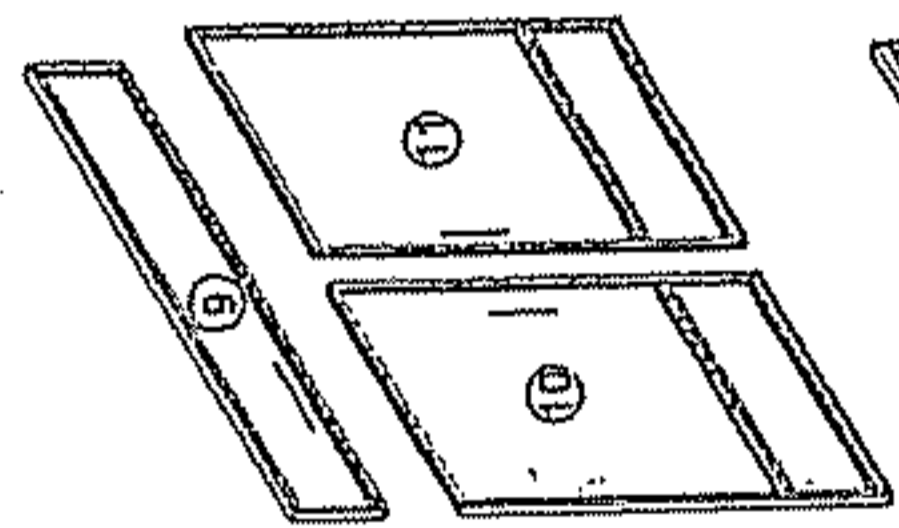
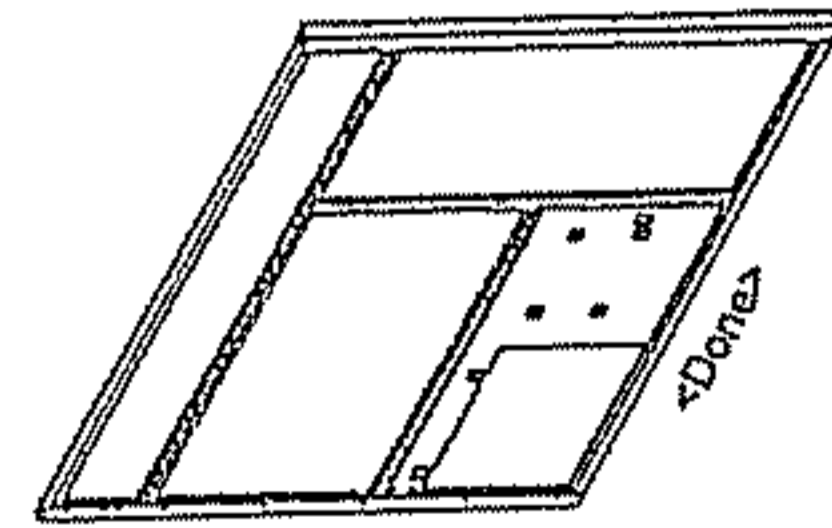

Assembly step:
 a. First assemble 10, 11
 b. Connecting along with arrow direction 9

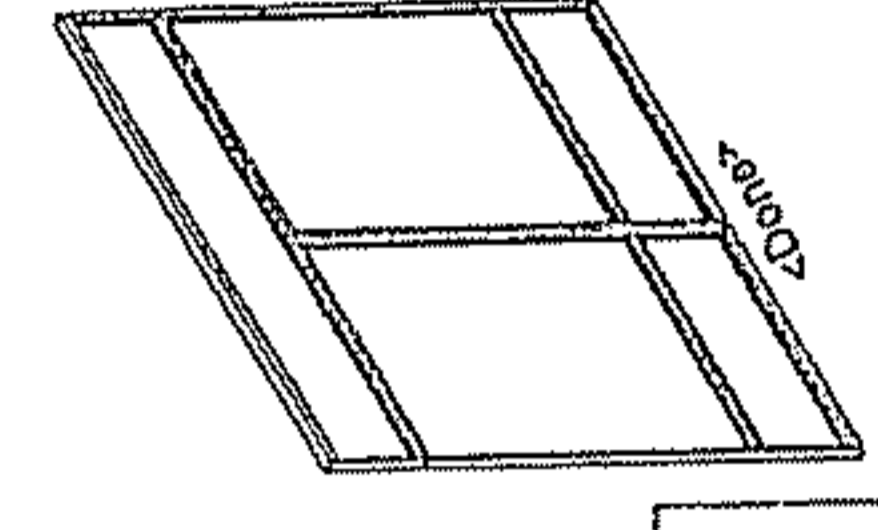

Assembly step:
 a. First assemble 3, 4
 b. Then connecting along with arrow direction 2

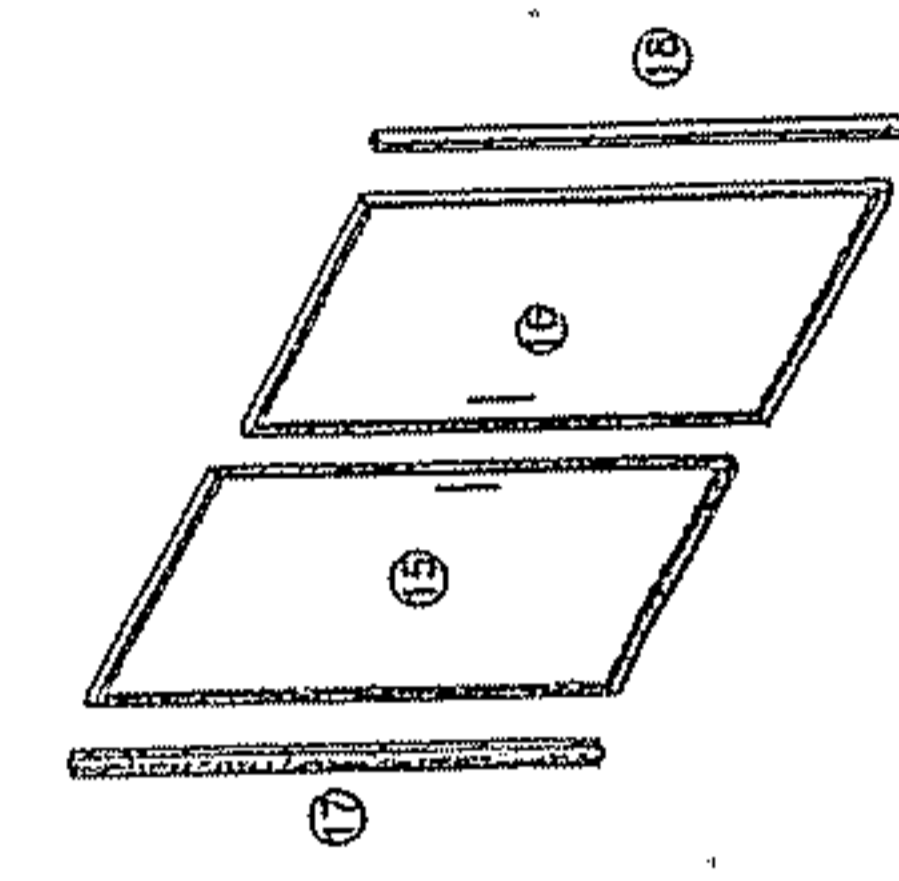

Assembly step:
 a. Fix 15 and 17 with screw I-1
 b. Then fix 16 and 18 with screw I-1
 c. Assemble 15 and 16 by drawing direction

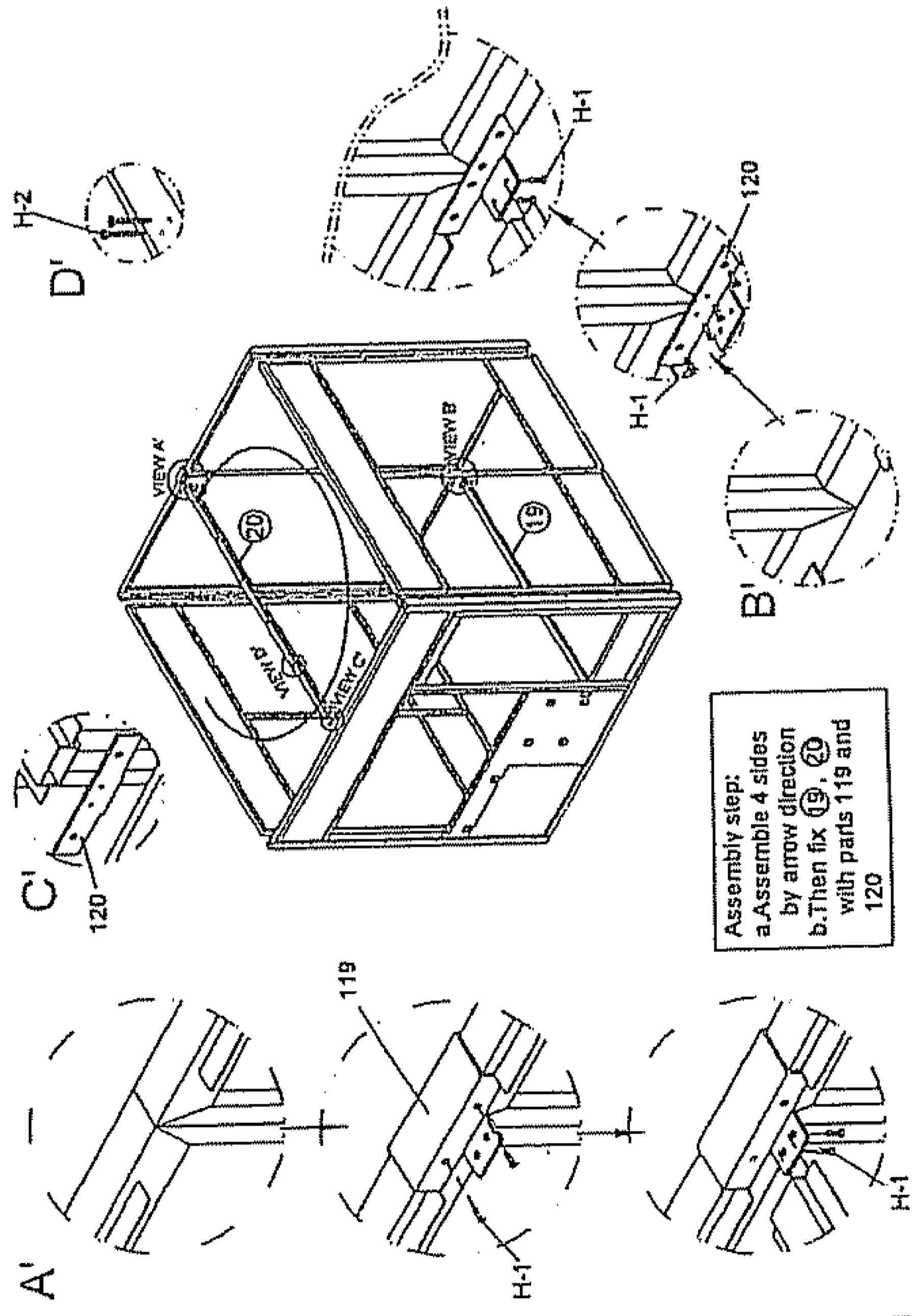
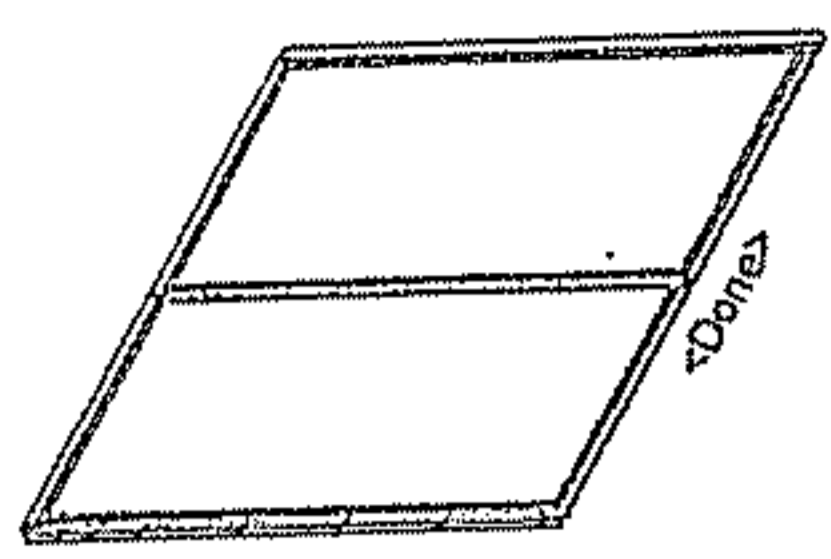

Assembly step:
 a. Assemble 4 sides by arrow direction
 b. Then fix 19, 20 with parts 119 and 120

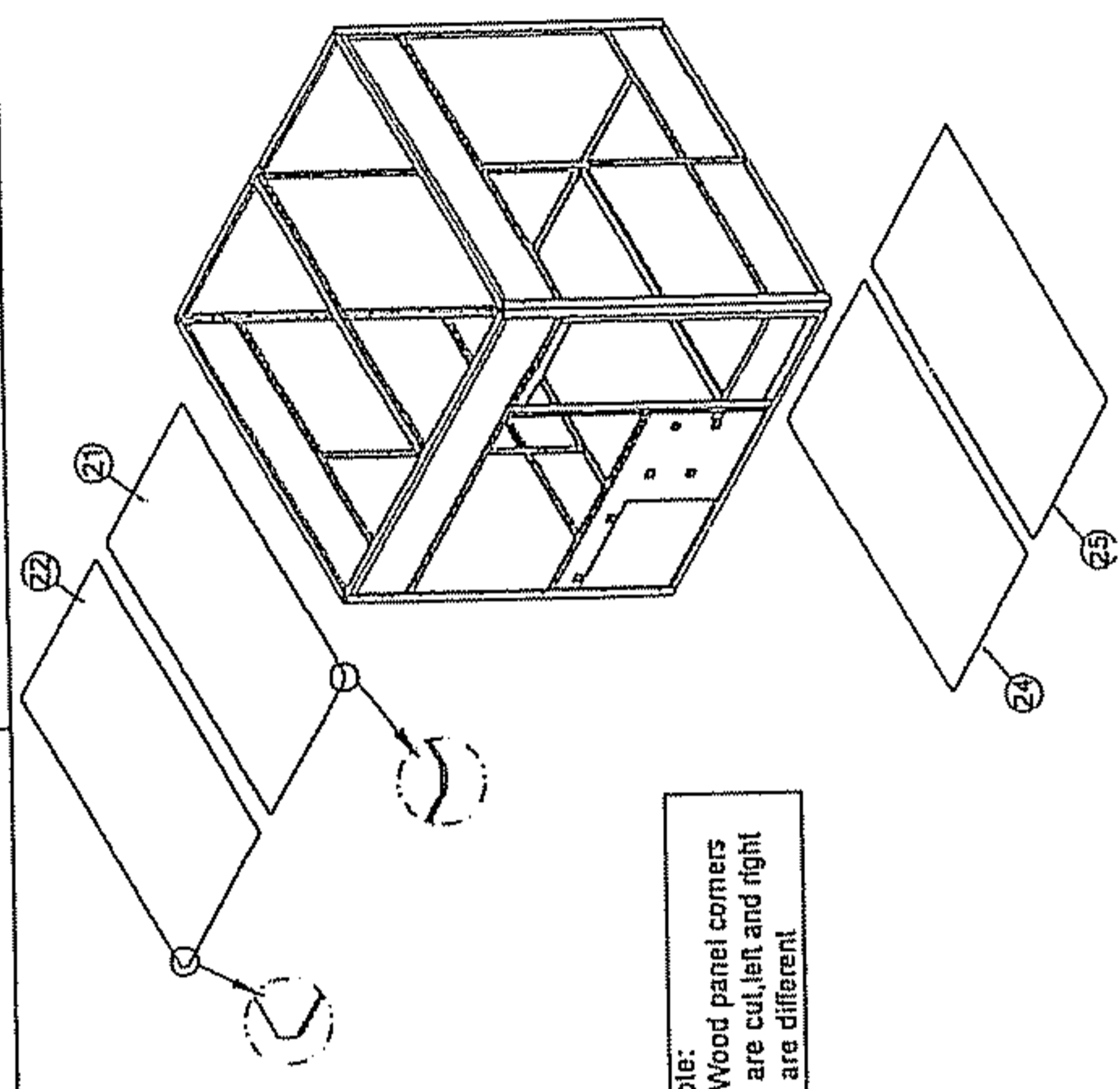

Note:
 a. Wood panel corners are cut, left and right are different

Need to measure distance and horizon of a, b, c.
 Please do the needful, ensure the gantry
 mechanism goes well after assembly.

Please note during direction of 23-1, 23-2
 "A" label close to front door
 "B" label close to back wall

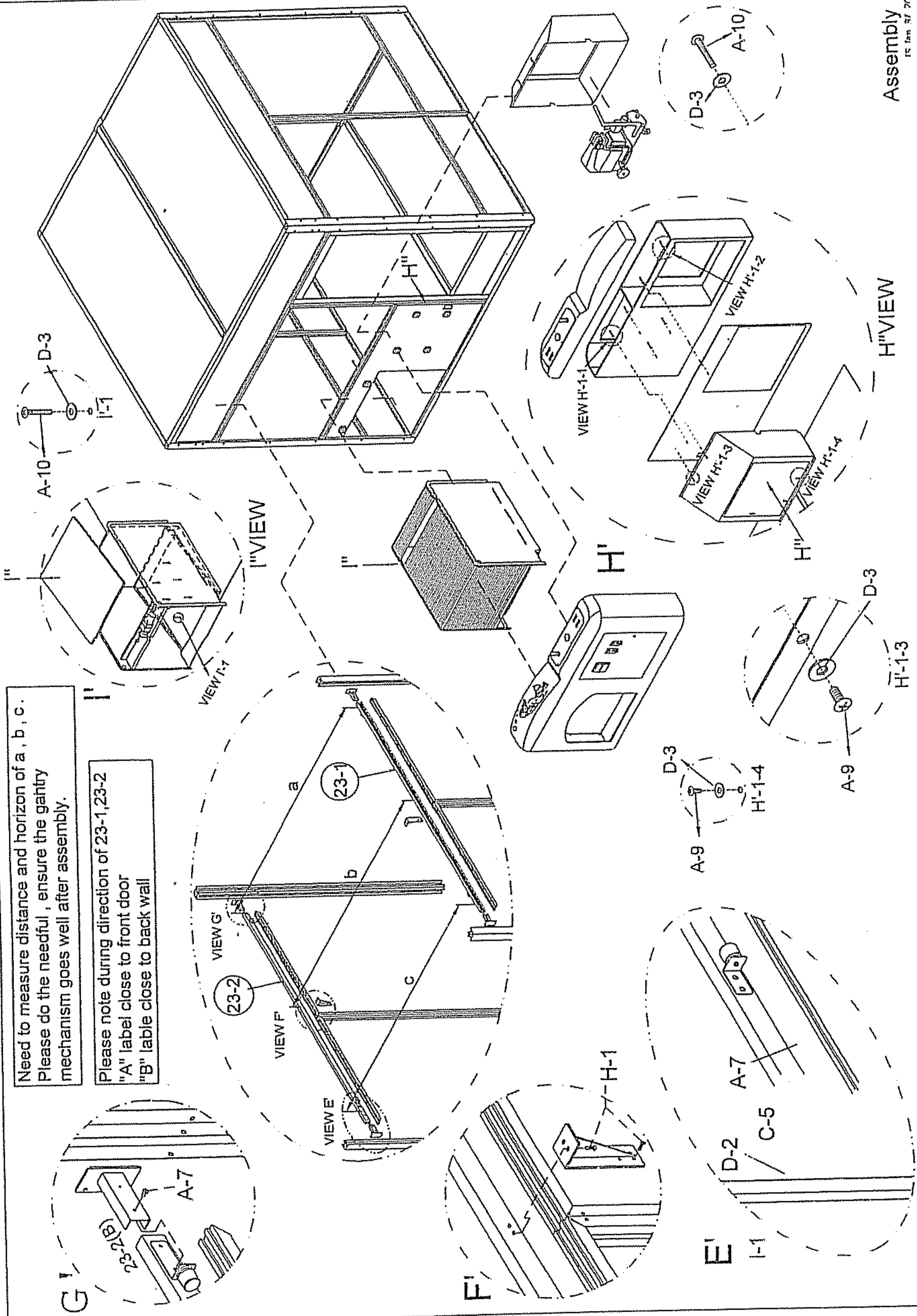

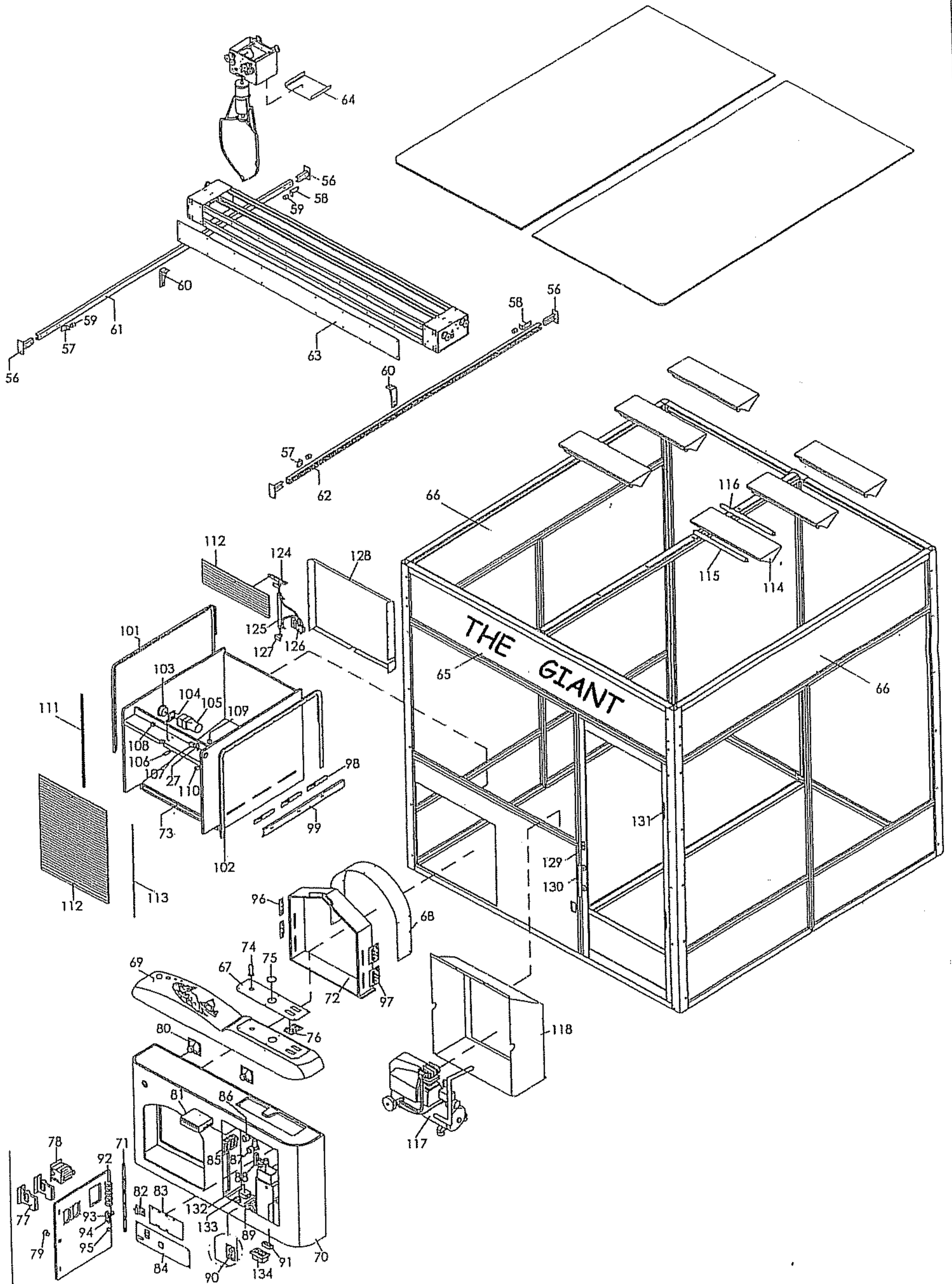

- B - Gantry
- 2 .Air pipe
- 3 .9 PIN-Male connector (8 wires) -Gantry motor
- 4 .9 PIN-Female connector (9 wires)
- Front back left right up down SW
- C - Left top panel lamp(Wire shorter end)
- D - Right top panel lamp (Wire longer end)

- A - Control box ->Gantry
- 1 .Lamp
- 2 .Air pipe
- 3 .9 PIN-male connector (8 wires) - Gantry motor
- 4 .9 PIN-female connector (9 wires)
- Front back left right up down SW
- A' - Control box ->Exit Box
- 1 .Lamp
- 2 .Air pipe
- 3 .9 PIN-female connector (8 wires) - Gantry motor
- 4 .9 PIN-male connector (9 wires)
- Front back left right up down SW
- 5 .Air pipe
- 6 .2 PIN -Air power
- 7 .3 PIN -Exit updown motor
- 8 .4 PIN -Exit detecting sensor
- 9 .12 PIN (9 wires) -Detecting sensor power

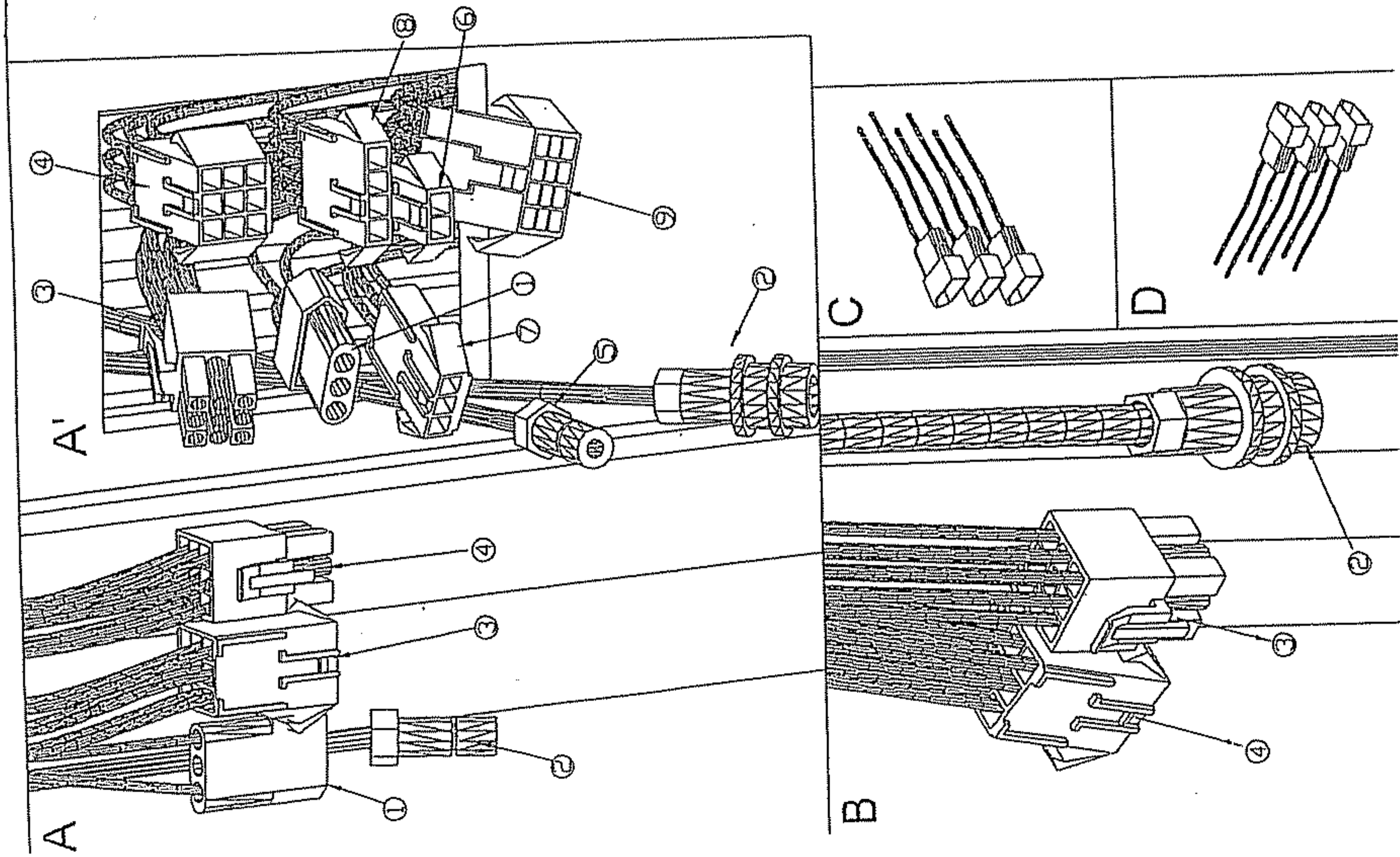
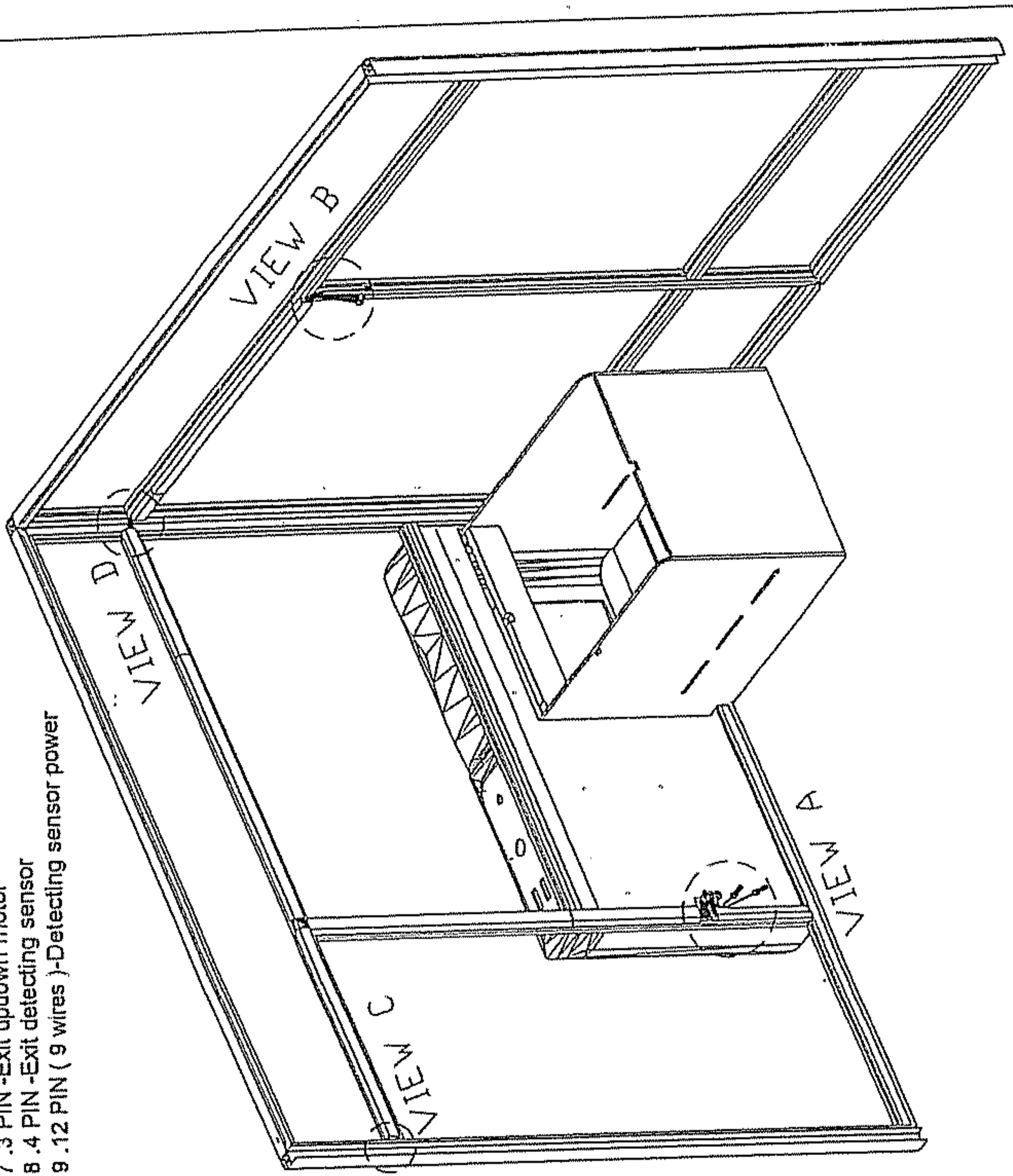

The Giant

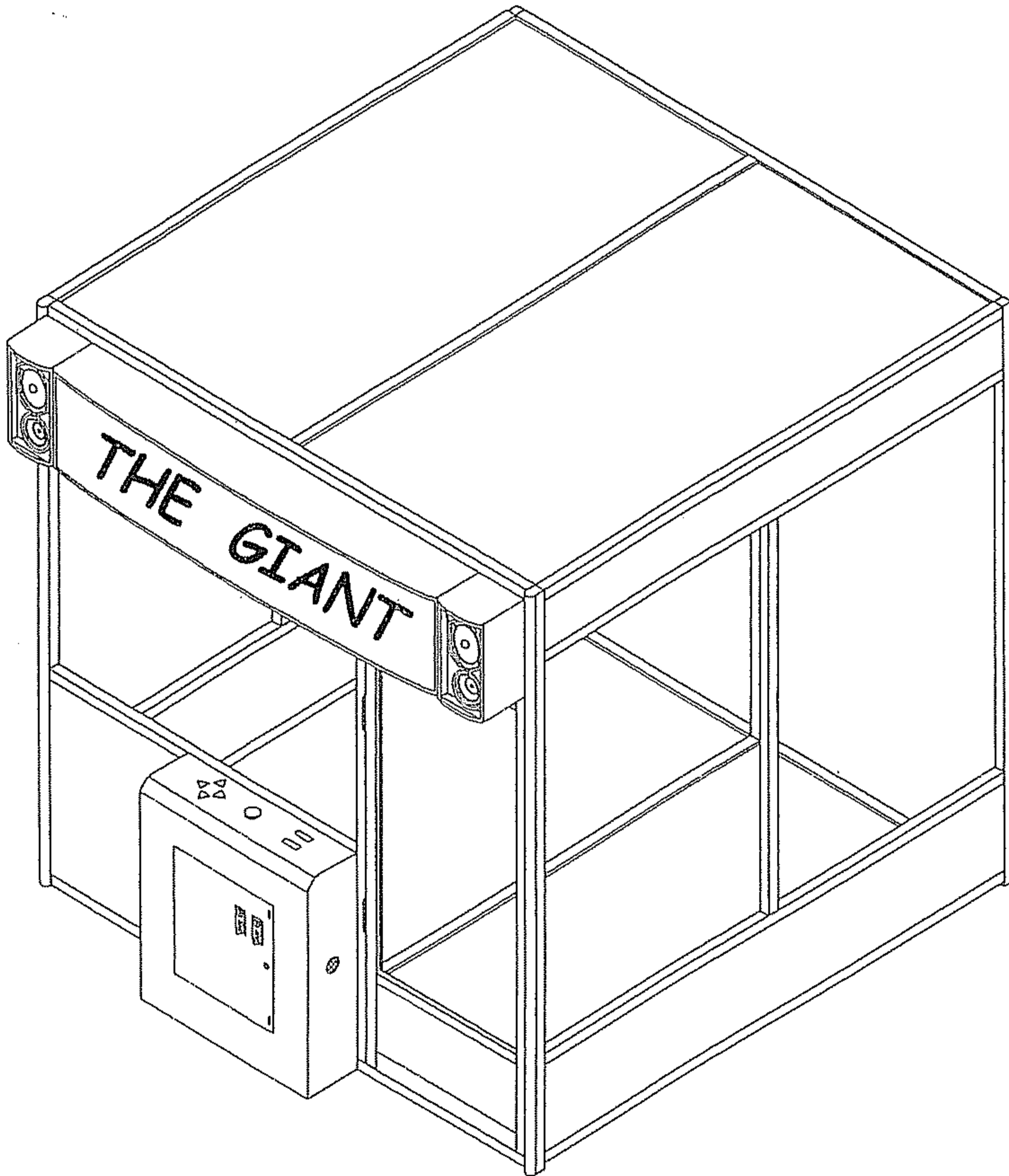

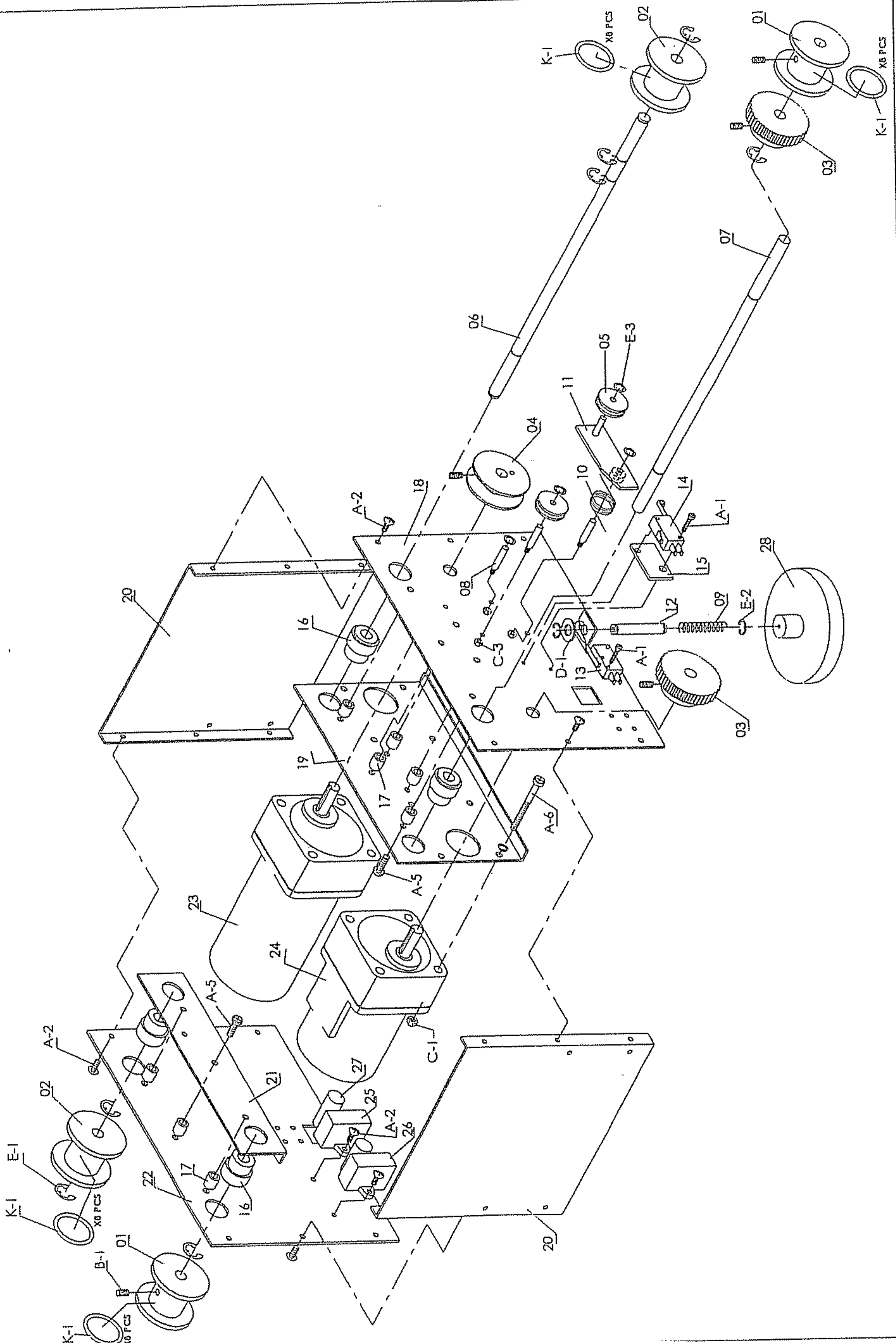

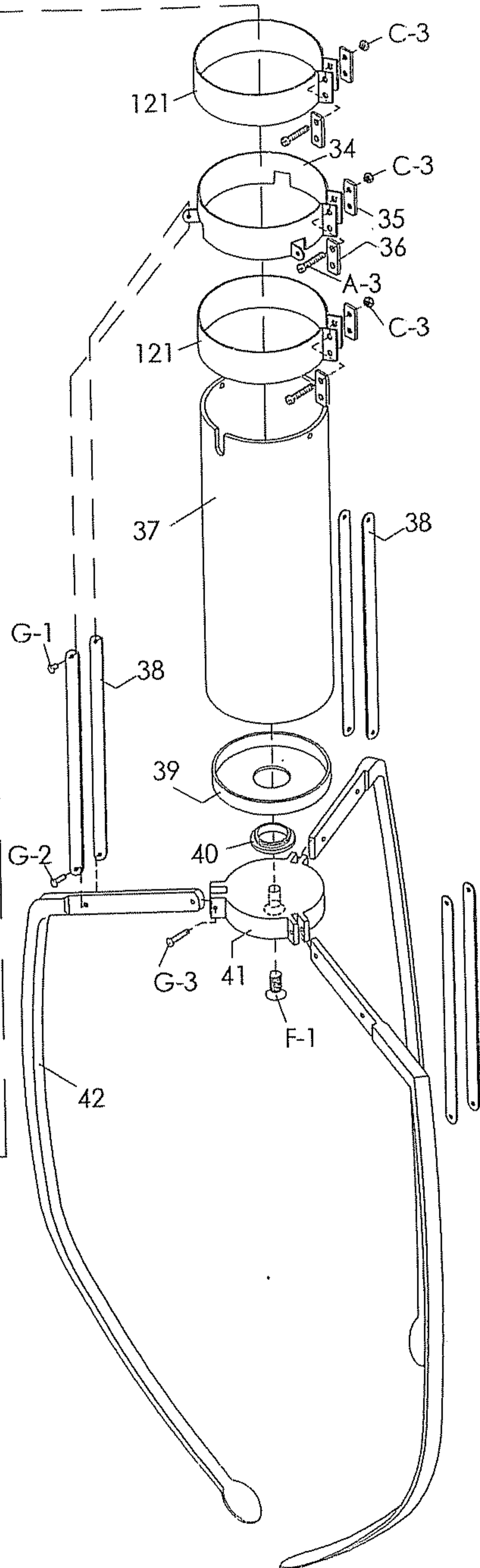
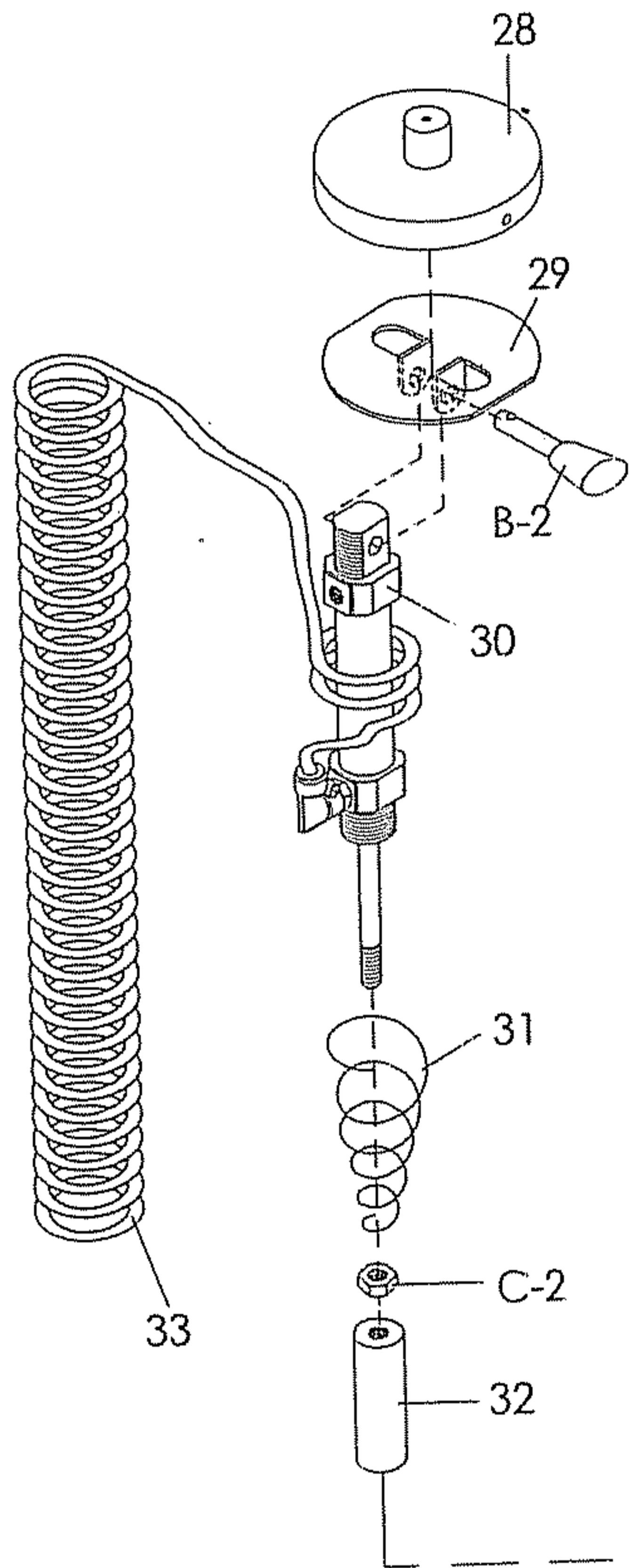

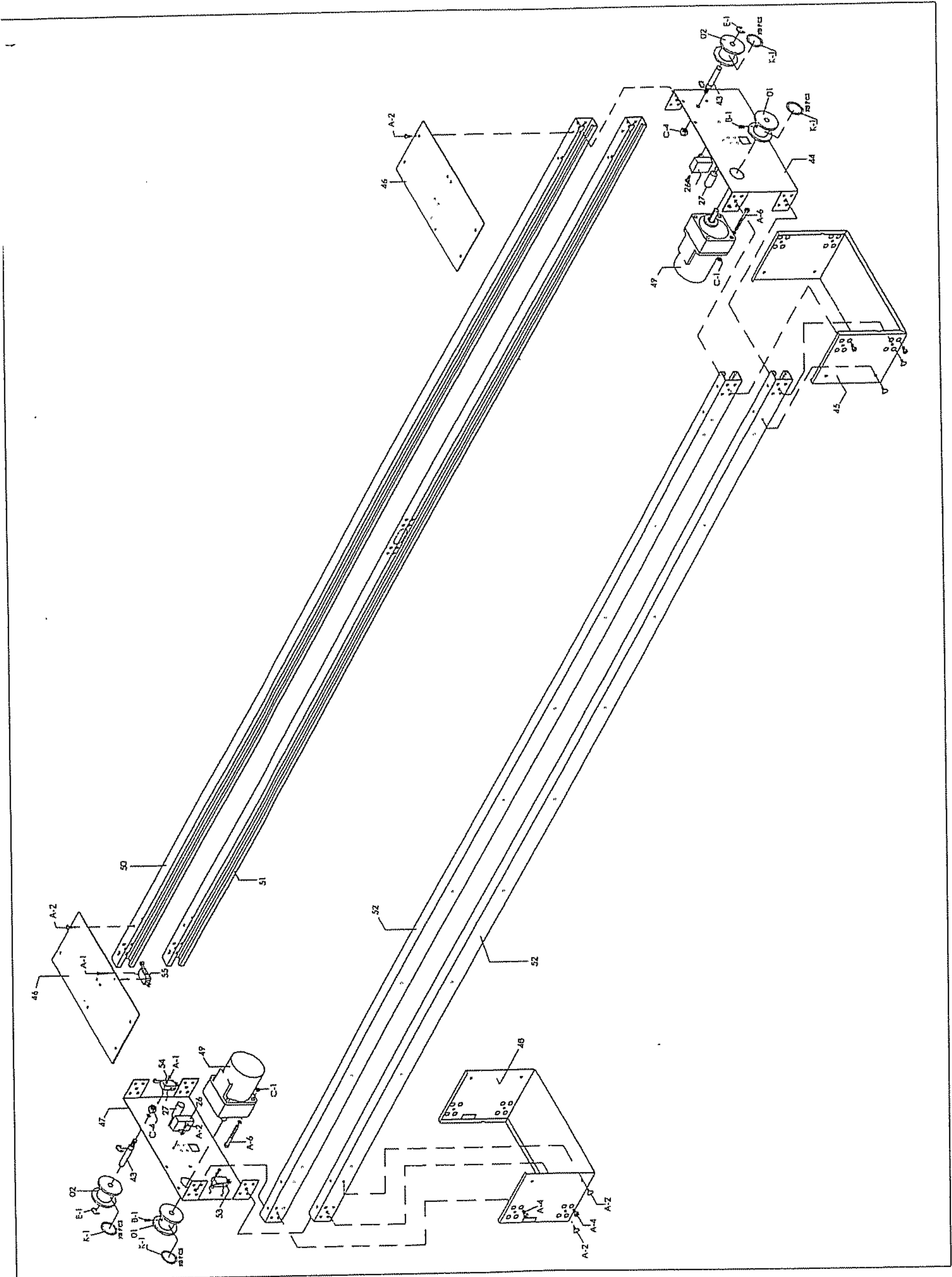

White fix tube & related positions

- L1 . 100 cm
- L2 . 49 cm.
- L3 . 47.5 cm
- L4 . 13.5 cm
- L5 . 80 cm

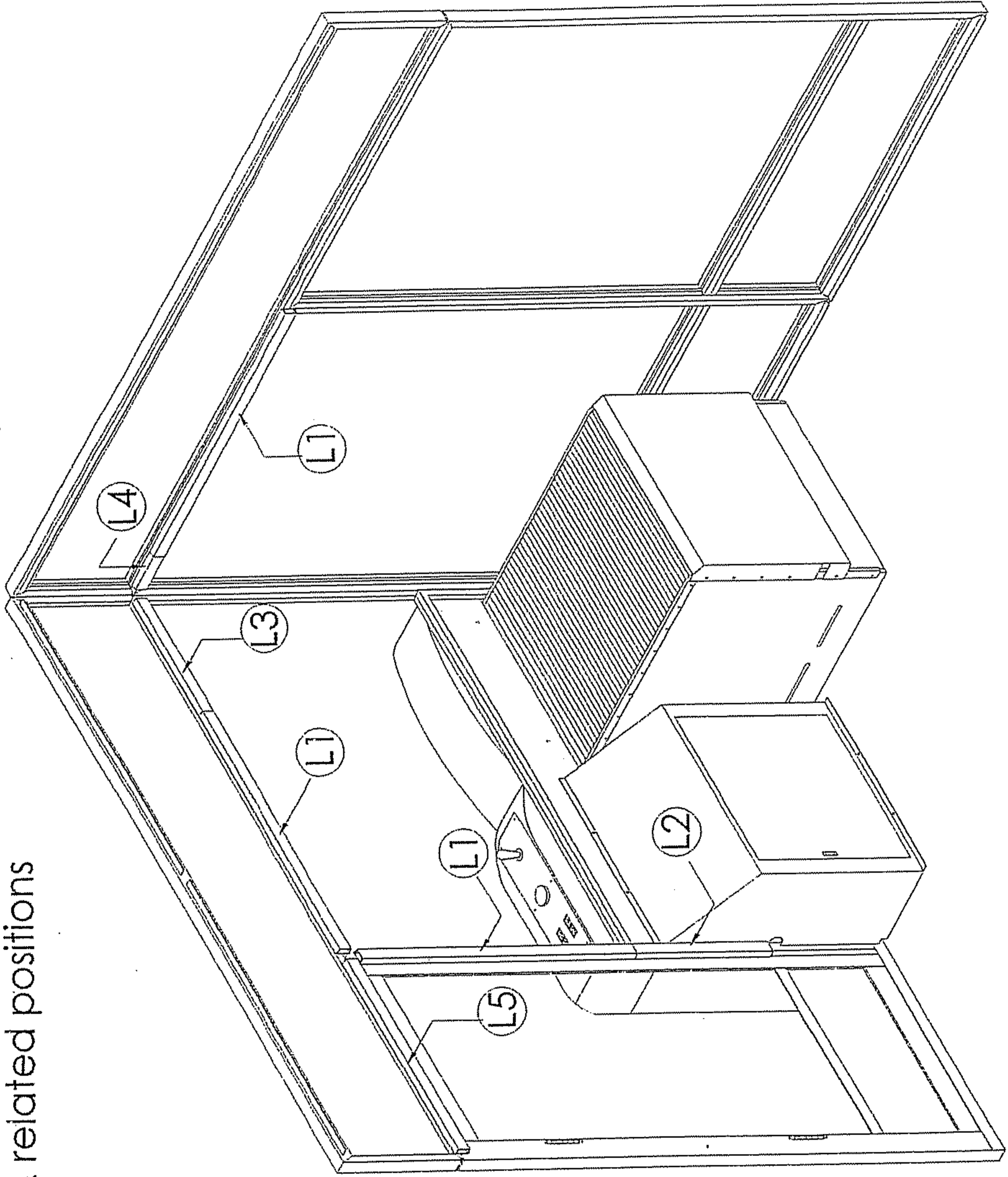

Wiring Configuration

- A. To control box
- B. To gantry connector
- C. To left top panel lamp
- D. To right top panel lamp

NOTE: LEFT WIRE SHORTER
RIGHT WIRE LONGER

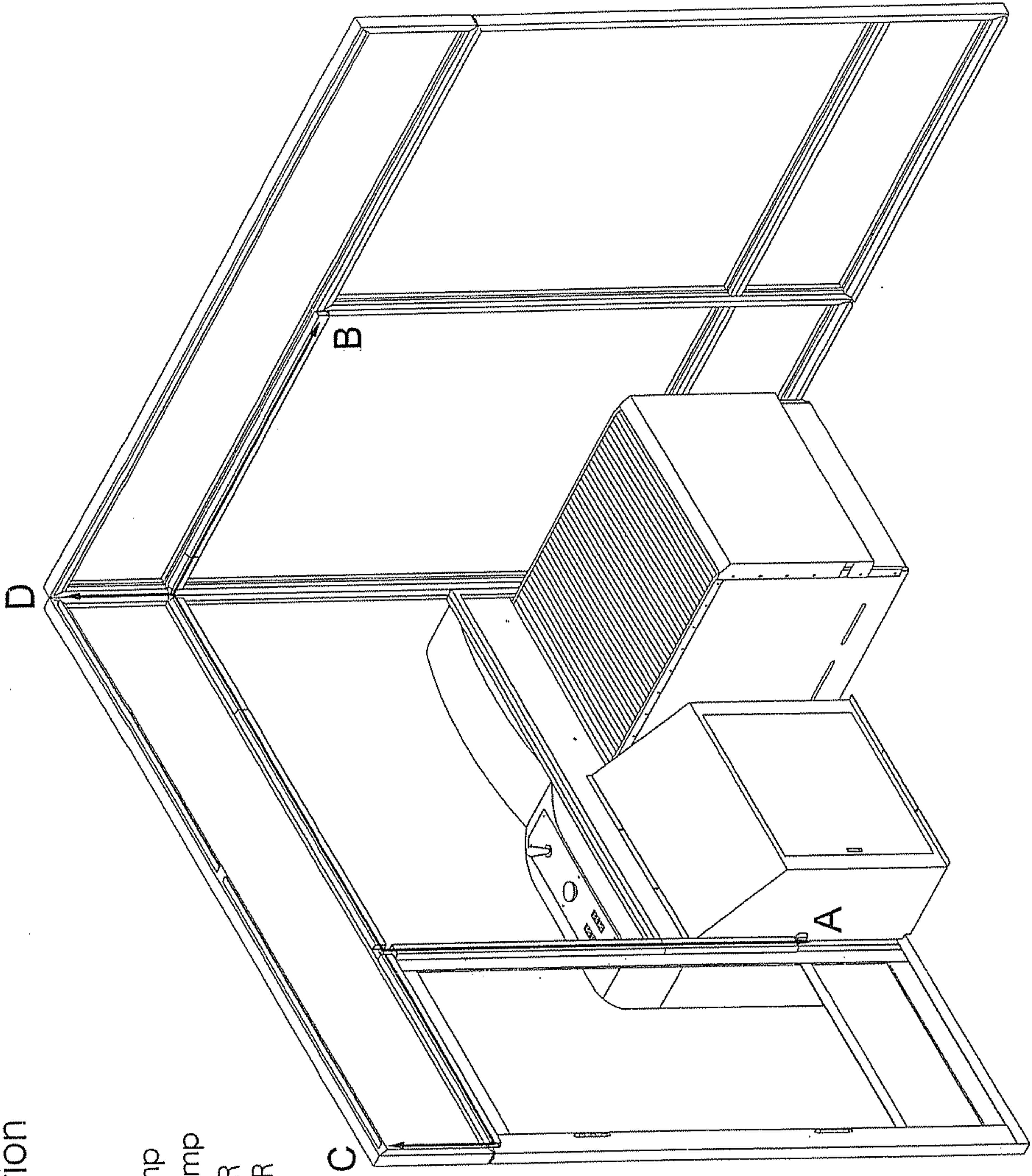

※ NOTE
1.DISPLAY

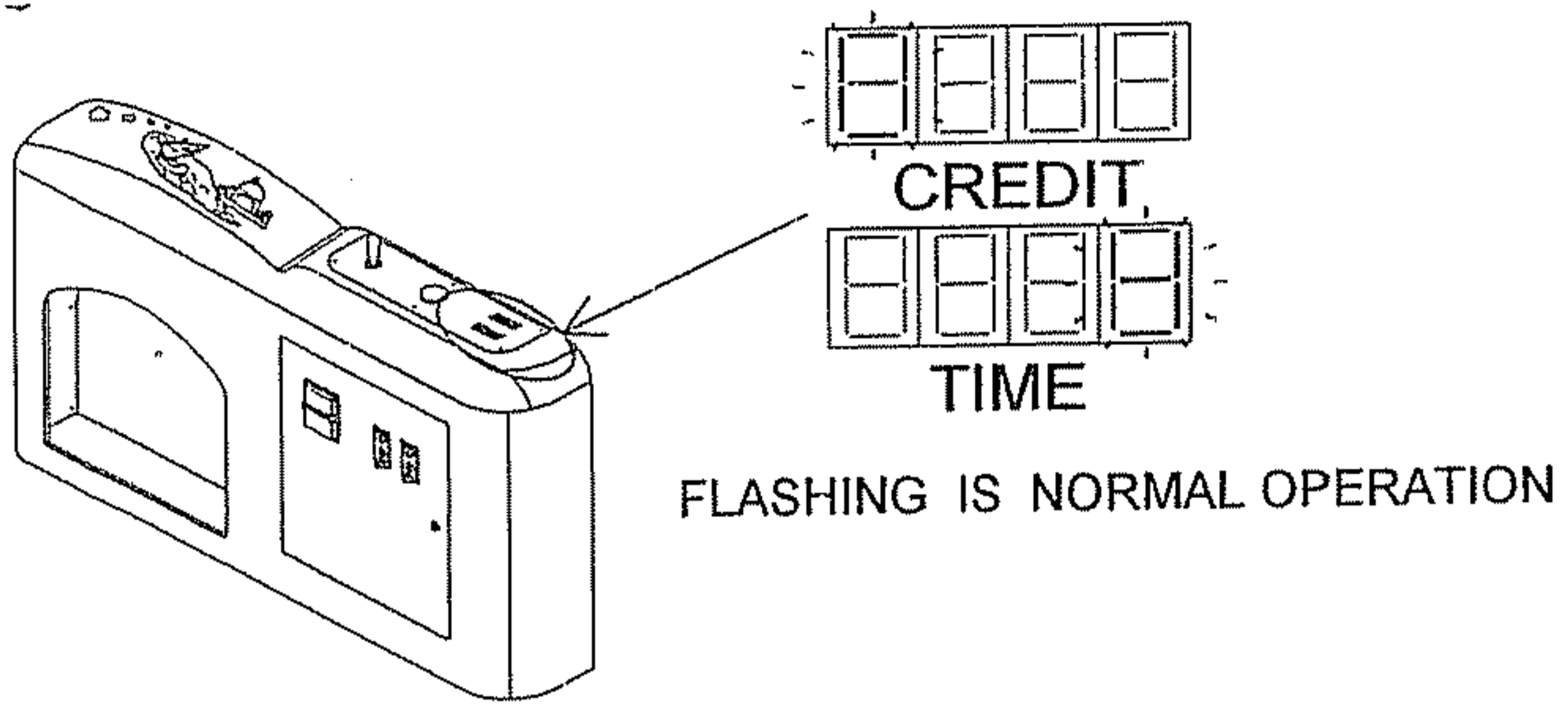

2.Gantry connector

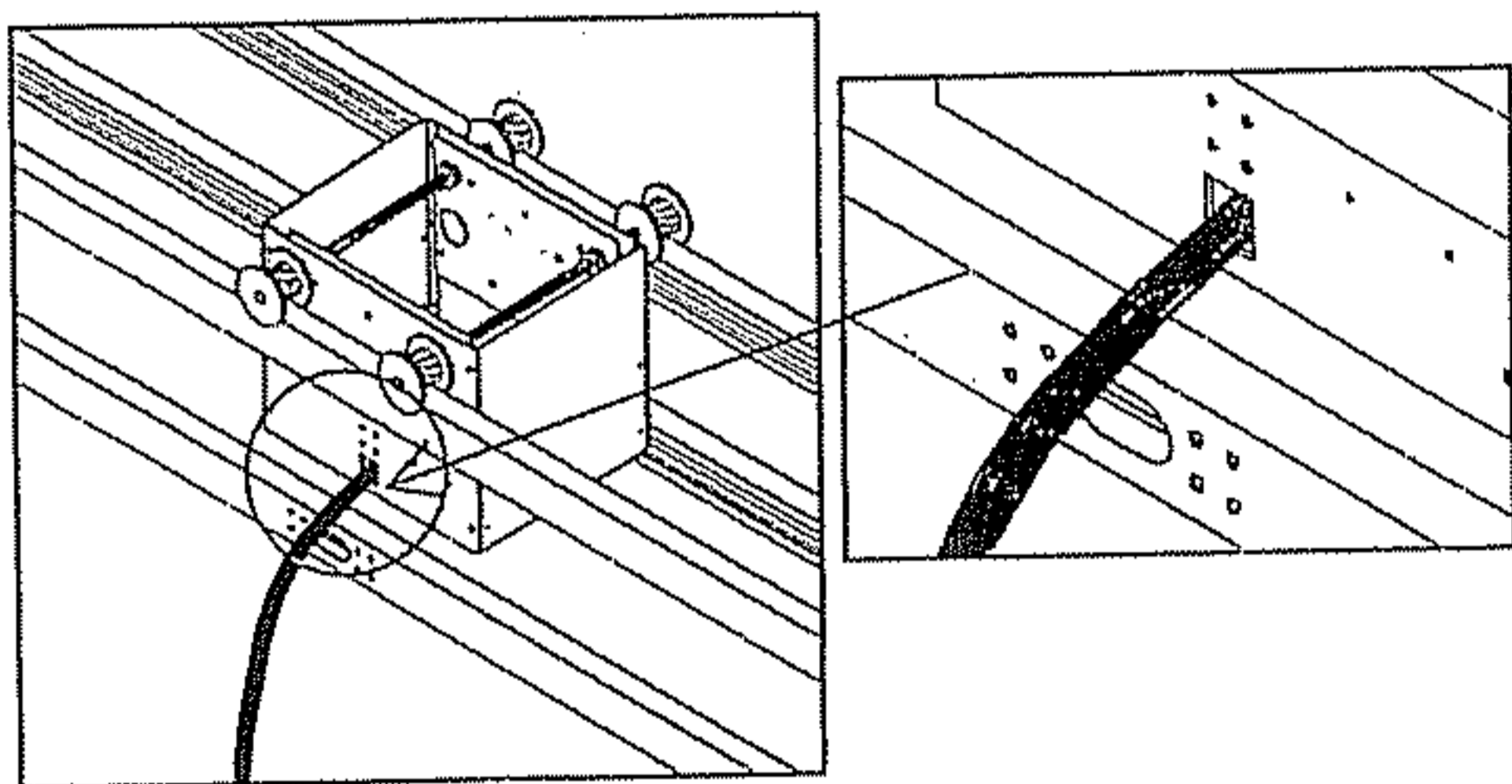
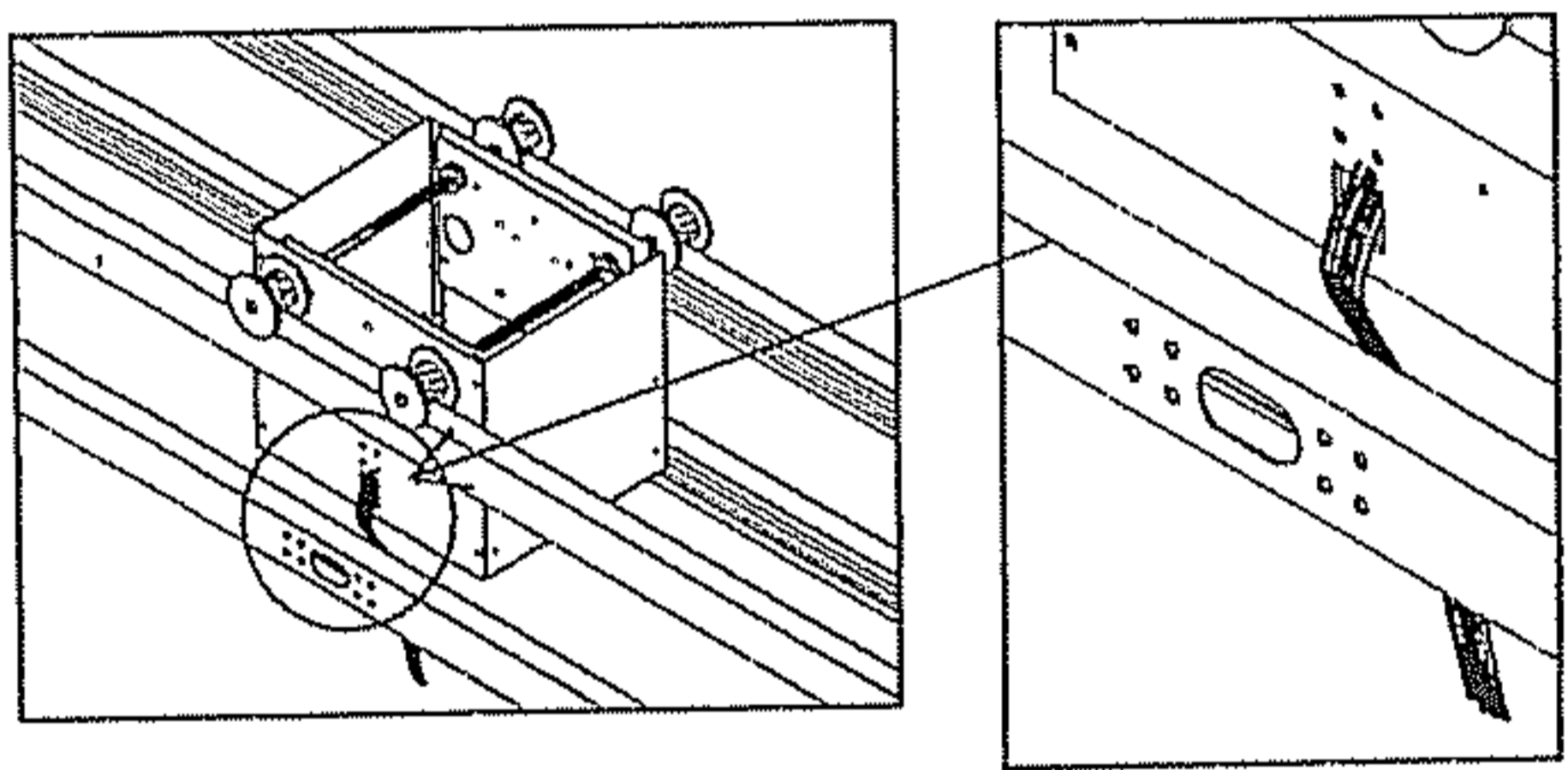

Exit back door

components description

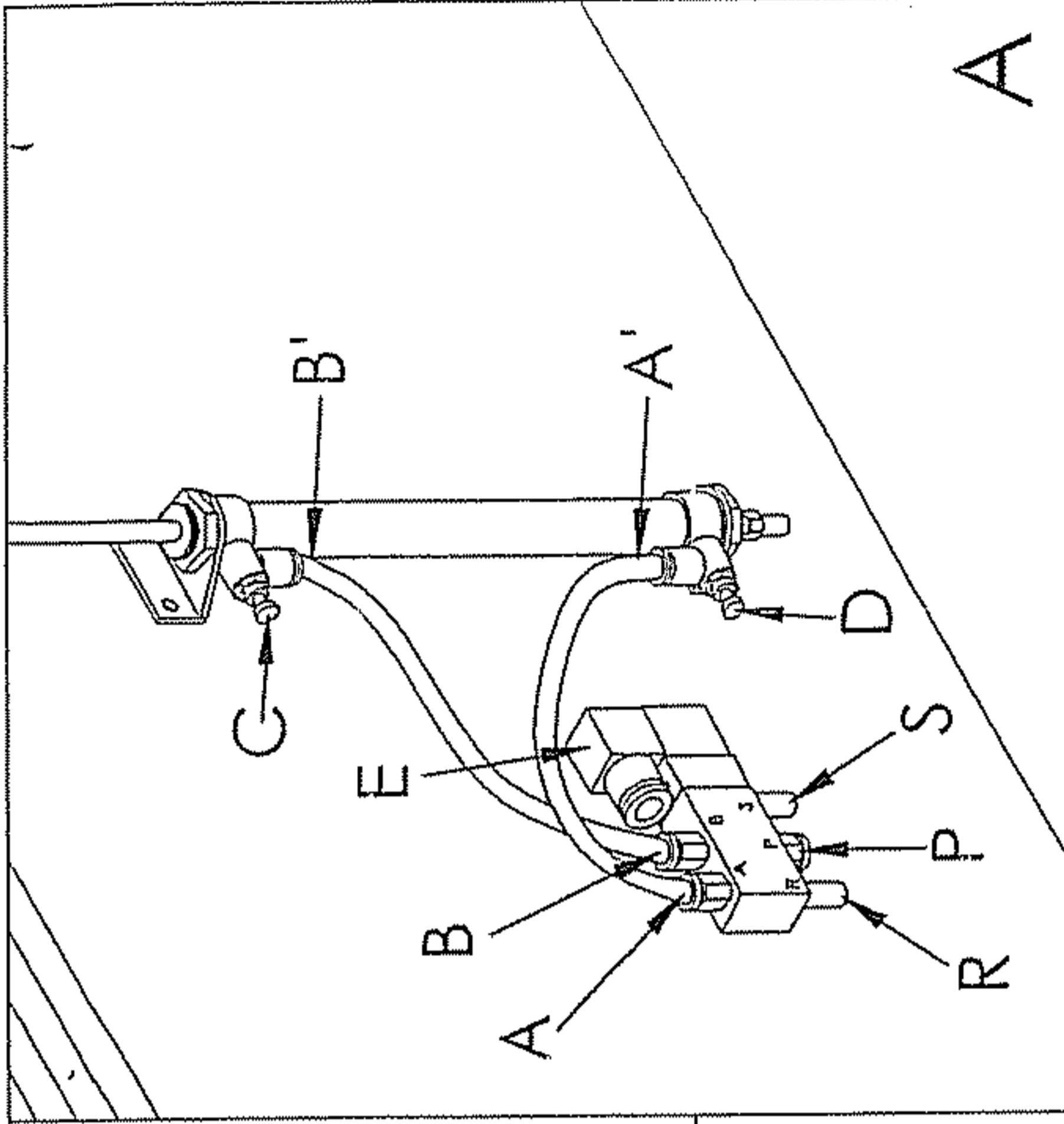
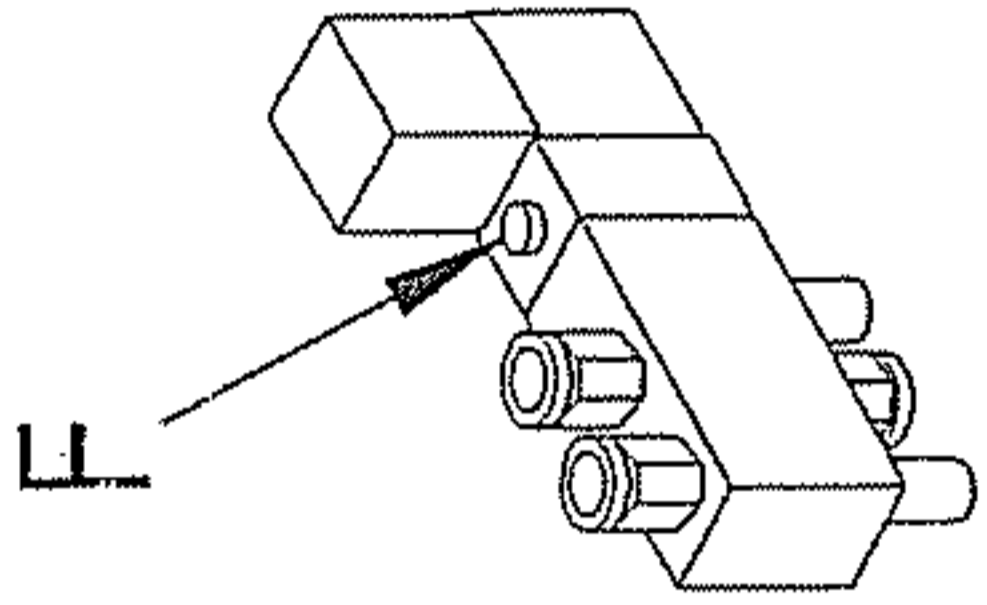
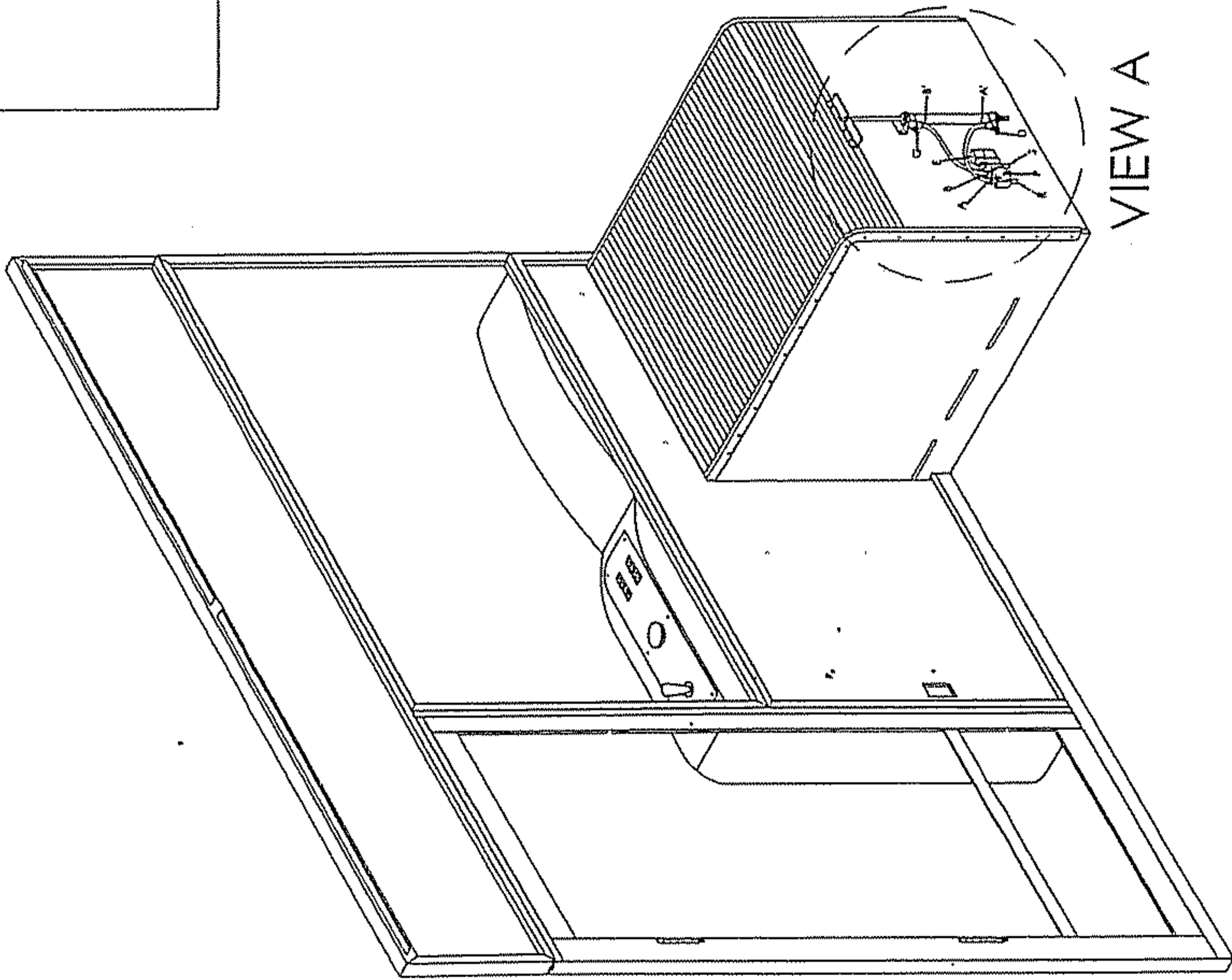

- ① R- Absorb air
S- Release air
P- Main air pipe hole
F- Air release button
- ② Air goes up from P→A→A'
Air goes down from P→B→B'
- ③ LED light on E position
- ④ C&D -adjust air

Grounding illustration

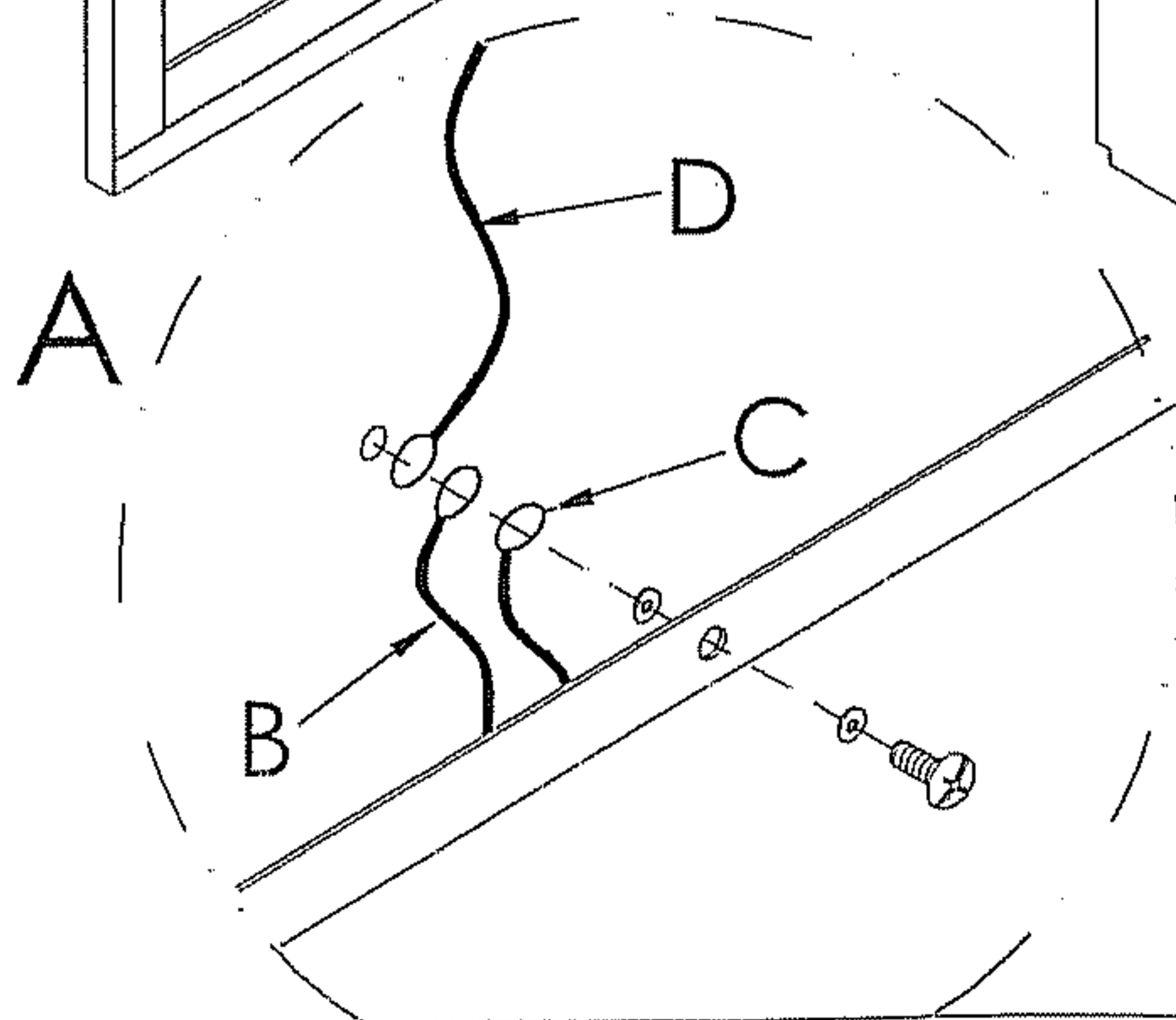
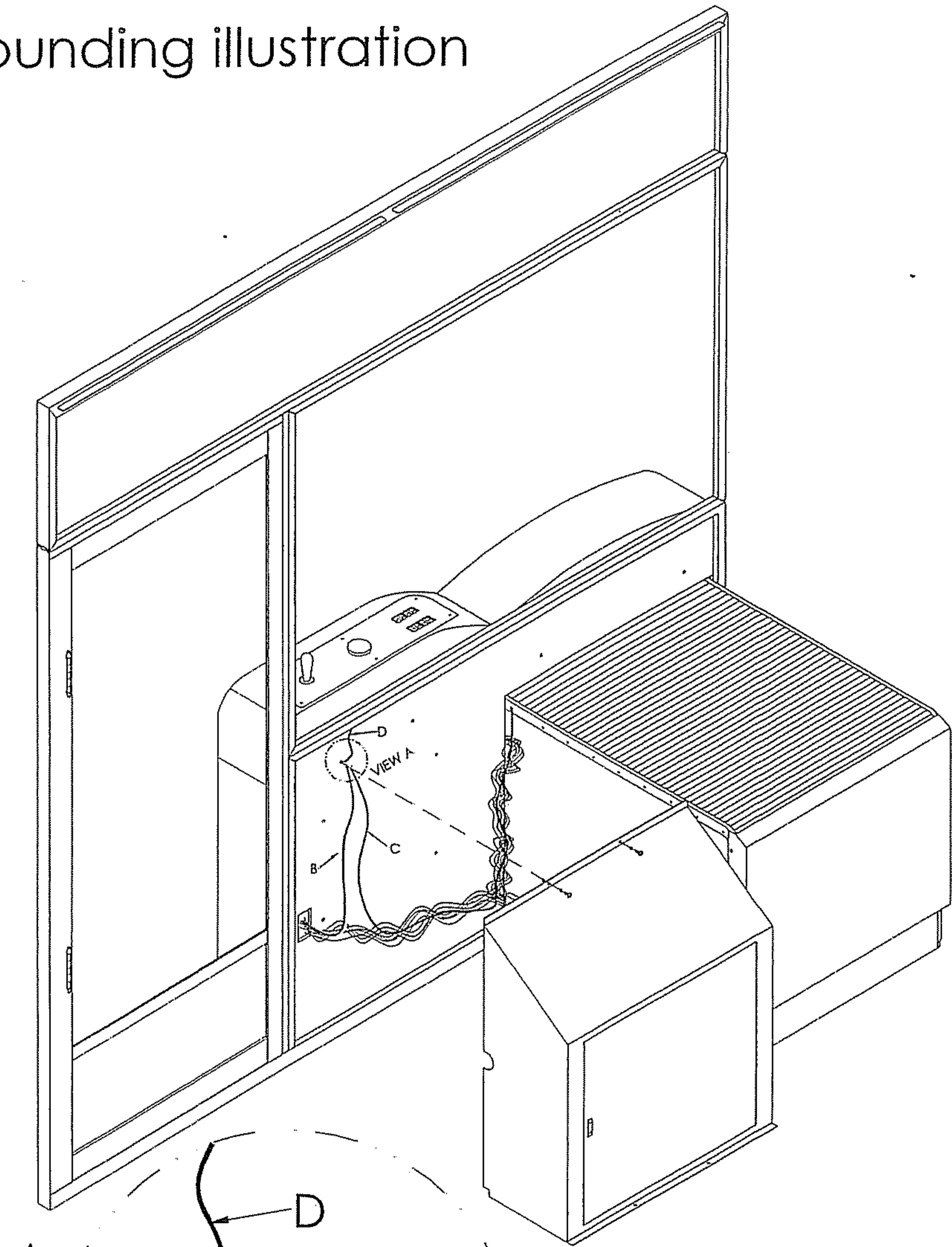

- B — Front Control grounding
- C — Metal grounding
- D — Gate door grounding

○ B、C、D
Per A, screw at A position
Fix tight means grounding