

NBA Hoops

Officially Licensed
NBA™ Product!



OWNERS AND SERVICE MANUAL INNOVATIVE CONCEPTS IN ENTERTAINMENT INC.

10123 MAIN STREET, CLARENCE, NY 14031

SERVICE: 1-716-759-0360

FAX: 1-716-759-0884

E-MAIL: service@icegame.com

WEBSITE: www.icegame.com

Table of Contents

Safety and Power Requirement Statements	3
Parts Included	4
Game Features and Gameplay	5
Cabinet Setup	6 - 15
Skirt Install	16
Linking Setup	17
Programming	18 - 21
Marquee Programming	22 - 23
General Maintenance	24
Electronical Repairs	
Ball Gate Trouble Shooting Flow Chart	25
DBV INSTALL	26
UCL Specifications	27
Parts Diagrams	28 - 35
Decal location diagram and part numbers	36
Spare Parts Listing	37
Warranty	38

SAFETY AND WARNINGS BEFORE YOU BEGIN

WARNING: WHEN INSTALLING THIS GAME, A GROUNDED A.C. RECEPTACLE MUST BE USED. FAILURE TO DO SO COULD RESULT IN INJURY TO YOURSELF OR OTHERS. FAILURE TO USE A GROUNDED RECEPTACLE COULD ALSO CAUSE IMPROPER GAME OPERATION, OR DAMAGE TO THE ELECTRONICS.

NOTE: THIS GAME IS INTENDED FOR INDOOR USE ONLY.

DO NOT DEFEAT OR REMOVE THE GROUNDING PRONG ON THE POWER CORD FOR THE SAME REASON AS GIVEN ABOVE. USING AN IMPROPERLY GROUNDED GAME COULD VOID YOUR WARRANTY.

HAVE A QUALIFIED ELECTRICIAN CHECK YOUR A.C. RECEPTACLE TO BE SURE THE GROUND IS FUNCTIONING PROPERLY.

THIS GAME IS DESIGNED TO DISSIPATE STATIC ELECTRICITY THROUGH THE GROUNDING PLANE OF THE GAME. IF THE A.C. GROUND DOES NOT WORK, THE GAME COULD DISCHARGE STATIC ELECTRICITY THROUGH THE GAME CIRCUITRY, WHICH COULD CAUSE DAMAGE.

THE POWER SUPPLY IS NOT VOLTAGE ADJUSTABLE. TO OPERATE THE GAME AT VOLTAGES OTHER THAN THOSE IT WAS DESIGNED FOR. PLEASE CONTACT OUR SERVICE DEPARTMENT FOR VOLTAGE CONVERSION INFORMATION.

WARNING

DO NOT remove any of the components on the main board (e.g. compact flash and EPROMS) while the game is powered on. This may cause permanent damage to the parts and the main board. Removing any main board component part while powered on will void the warranty.

ALWAYS REMOVE POWER TO THE GAME, BEFORE ATTEMPTING ANY SERVICE, UNLESS NEEDED FOR SPECIFIC TESTING. FAILURE TO OBSERVE THIS PRECAUTION COULD RESULT IN SERIOUS INJURY TO YOURSELF OR OTHERS.

THIS GAME IS NOT SUITABLE FOR INSTALLATION IN AN AREA WHERE A WATER JET COULD BE USED.

This appliance is not intended for use by persons (including children) with reduced physical, sensory or mental capabilities, or lack of experience and knowledge, unless they have been given supervision or instruction concerning use of the appliance by a person responsible for their safety. Children should be supervised to ensure that they do not play with the appliance.

AC Power Information

The games main fuse is accessed at the back of the game and at the power mod. Above the power cord is a small panel that contains the main fuse. The value of the fuse for 120 volt users is 3 AMPS at 250Volt type slow blow. The value of the fuse for 230 users is 1.5 AMPS at 250Volt type slow blow.



NBA Hardware Package

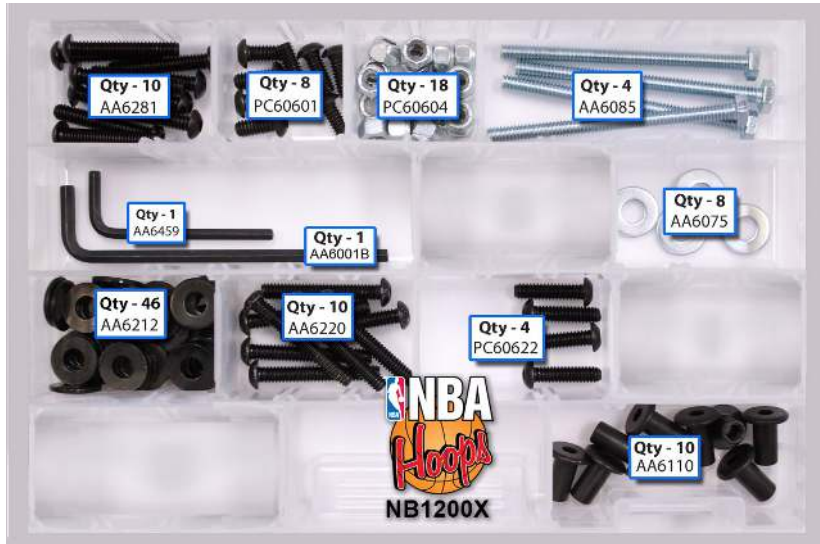

TOOLS NEEDED

- 7/16" Combination Wrench
- 7/16" Deep Well Socket
- Ratchet
- Side Cutters
- Adjustable Pliers
- #2 Square Drive Bit
- 5/32" Security Wrench
- 3/16 Allen Wrench

NOTE: Your hardware box might appear different.



Leg Caps

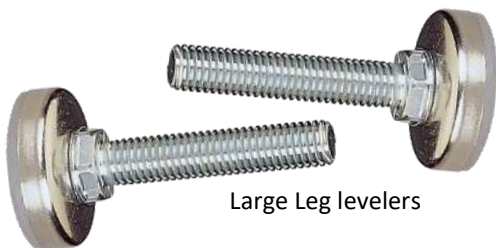

Large Leg levelers

Rebound guard brackets

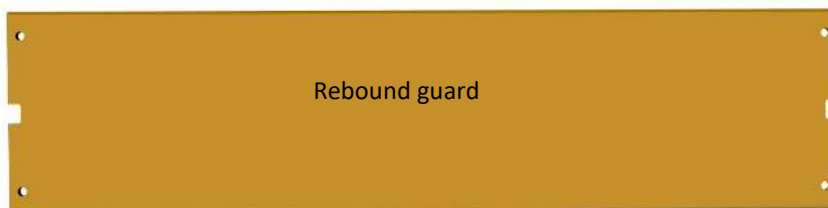

Rebound guard

GAME FEATURES

NBA HOOPS™ is a revolutionary concept in Coin Operated basketball games. You will see that this game includes many features which make it the obvious choice for your location.

NBA HOOPS™ incorporates a STATIONARY basket that is user friendly and realistic. Fun and easy to play for players of all ages, yet challenging enough for even the expert basketball players. Practice your basketball skills and try to better your last score or link more games to compete against other players.

- **CONTROL PANEL** uses a color LED display for scoring and vital information. The control panel is laid out in a convenient user friendly fashion, making it easy for players to operate.
- **HEAVY DUTY CONSTRUCTION** is incorporated throughout the game by using only heavy gage metals and plastics. The game can be assembled and disassembled many times without any harm to the game. You will appreciate this feature if you move your games often.
- **LINKING** - no hassle linking hardware. No software station ID's to setup. Up to 10 games game be linked with ease.

OPTIONS. A ticket dispenser and/or a dollar bill validator can be ordered with your game.

GAME PLAY

NBA HOOPS™ is a coin operated amusement game designed to be played by one player. It can be linked to other games for a maximum of ten games. This game is similar to our original basketball game already on the market. However, we have made this an even more exciting game. The net remains stationary as the player shoots over and over. Two points are awarded for each basket scored. When 10 seconds remain in the game, it awards the player three points for all baskets scored.

LINKING is a popular option used in locations where more than one game is to be used. The games are "linked" to add direct head to head action between the game players. This option is built into each Main PC Board.

BEFORE YOU BEGIN

WARNING: WHEN INSTALLING THIS GAME, A 3 PRONG GROUNDED A.C. RECEPTACLE MUST BE USED. FAILURE TO DO SO COULD RESULT IN INJURY TO YOURSELF OR OTHERS. FAILURE TO USE A GROUNDED RECEPTACLE COULD ALSO CAUSE IMPROPER GAME OPERATION, OR DAMAGE TO THE ELECTRONICS.

DO NOT DEFEAT OR REMOVE THE GROUNDING PRONG ON THE POWER CORD FOR THE SAME REASON AS GIVEN ABOVE. USING AN IMPROPERLY GROUNDED GAME COULD VOID YOUR WARRANTY.

HAVE A QUALIFIED ELECTRICIAN CHECK YOUR A.C. RECEPTACLE TO BE SURE THE GROUND IS FUNCTIONING PROPERLY.

Step 1:

Locate the two U-Shape legs and lay the cabinet on top of two basket balls (the balls will not be damaged). Insert the short U-shape leg into the front of the cabinet. Insert the long U-shape leg into the back of the cabinet.

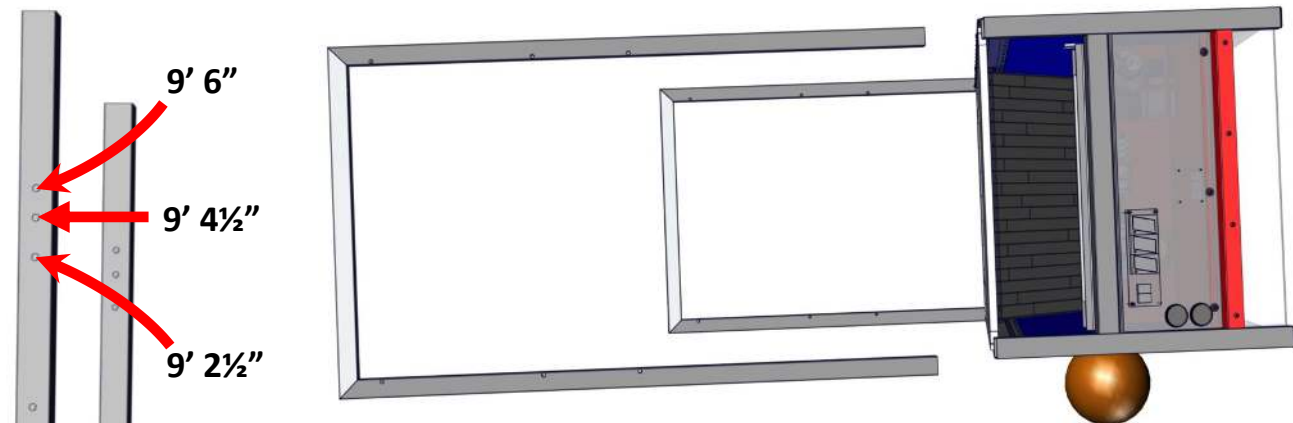
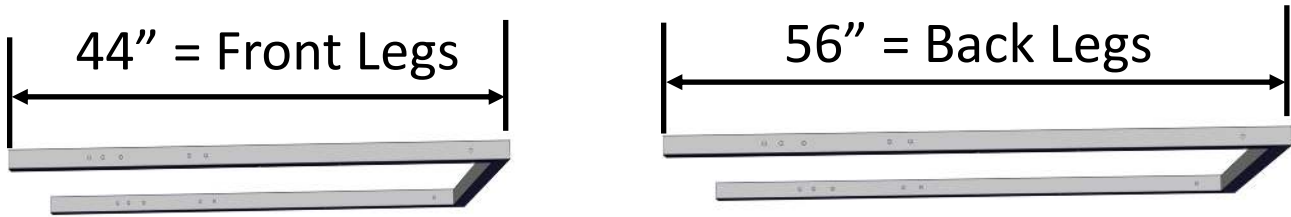

Basketball allows easy access to mounting holes!

Step 2:

A 10 foot ceiling height is recommended when using the 9' 6" mounting hole.

Whichever height you use you must use the same for each leg!

To secure the legs use one AA6110 Joint Connector on the outside. Then from the inside use one AA6212 black washer and AA6220 (¼-20" by 1¾") Allen bolt. Repeat for both sides, front and back.

Only tighten when all bolts are installed.

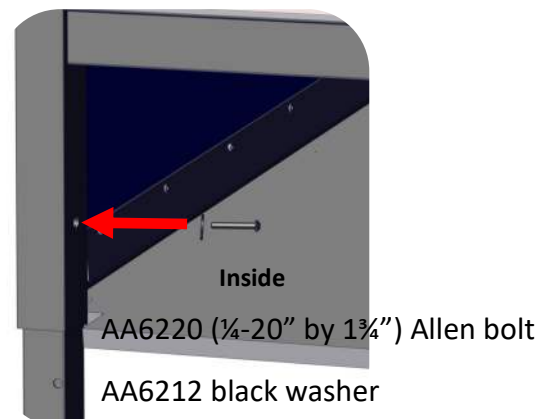
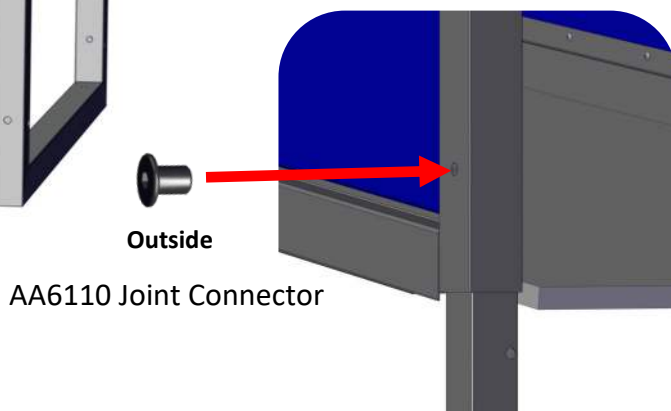

Step 3:

Unbox the cages position them as described below. The side cages go to the outside. The top cage mounts to the inside.

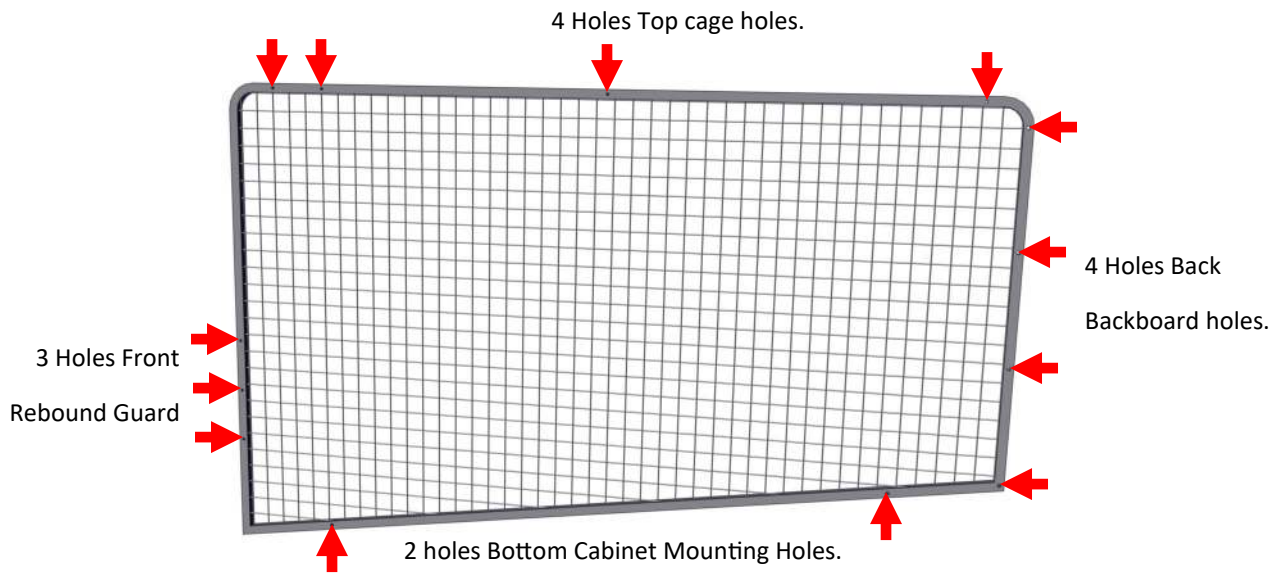

Beacon mount no longer on cage. Instead, front of cage top has metal strap for mounting the mega marquee legs.

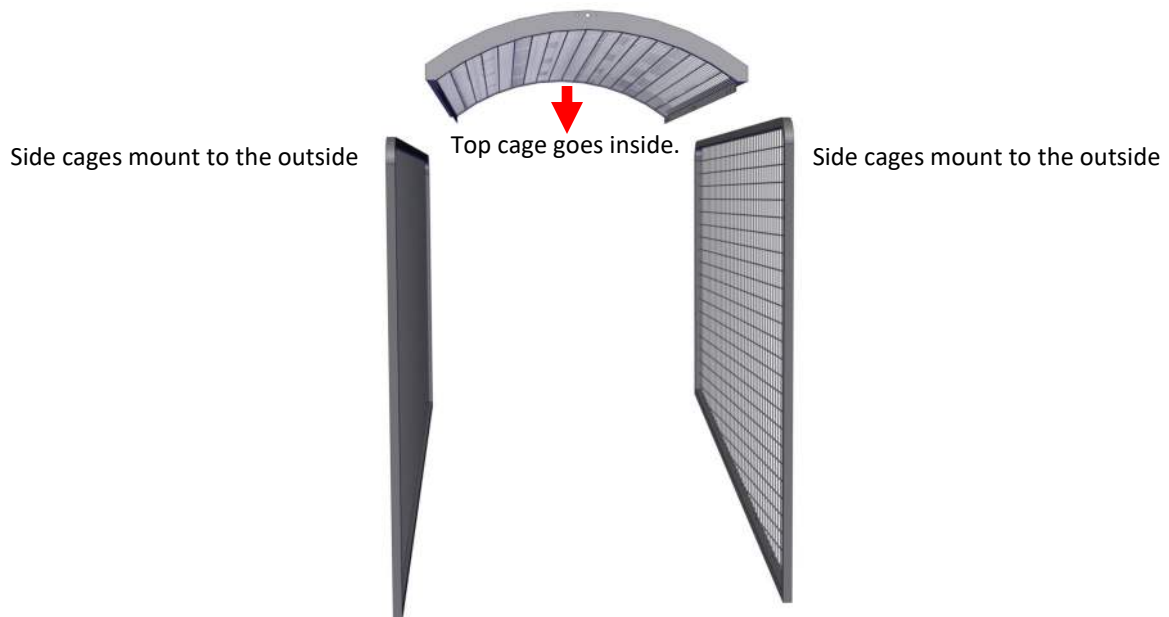
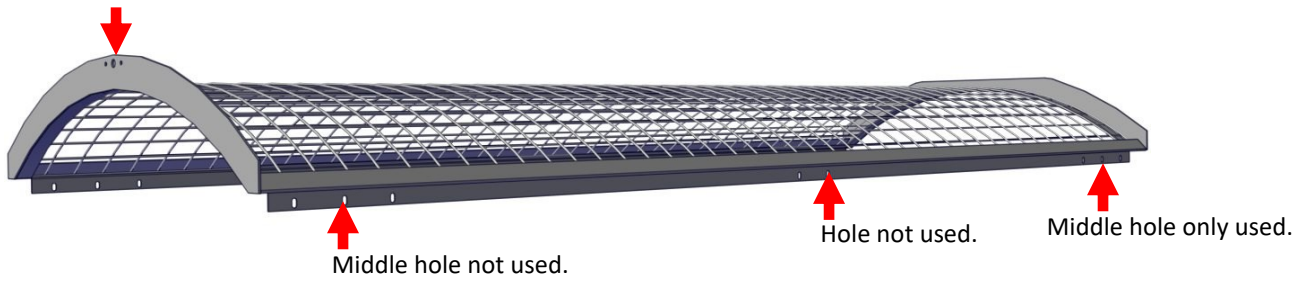

Step 4:

Attach the cages together using four AA6281 ¼-20 x 1" bolts with AA6212 black washers to the outside and secure them with PC60604 with AA6212 black washers on the inside.

DO NOT FULLY TIGHTEN BOLTS AT THIS TIME. You might have alignment issues later if tighten.

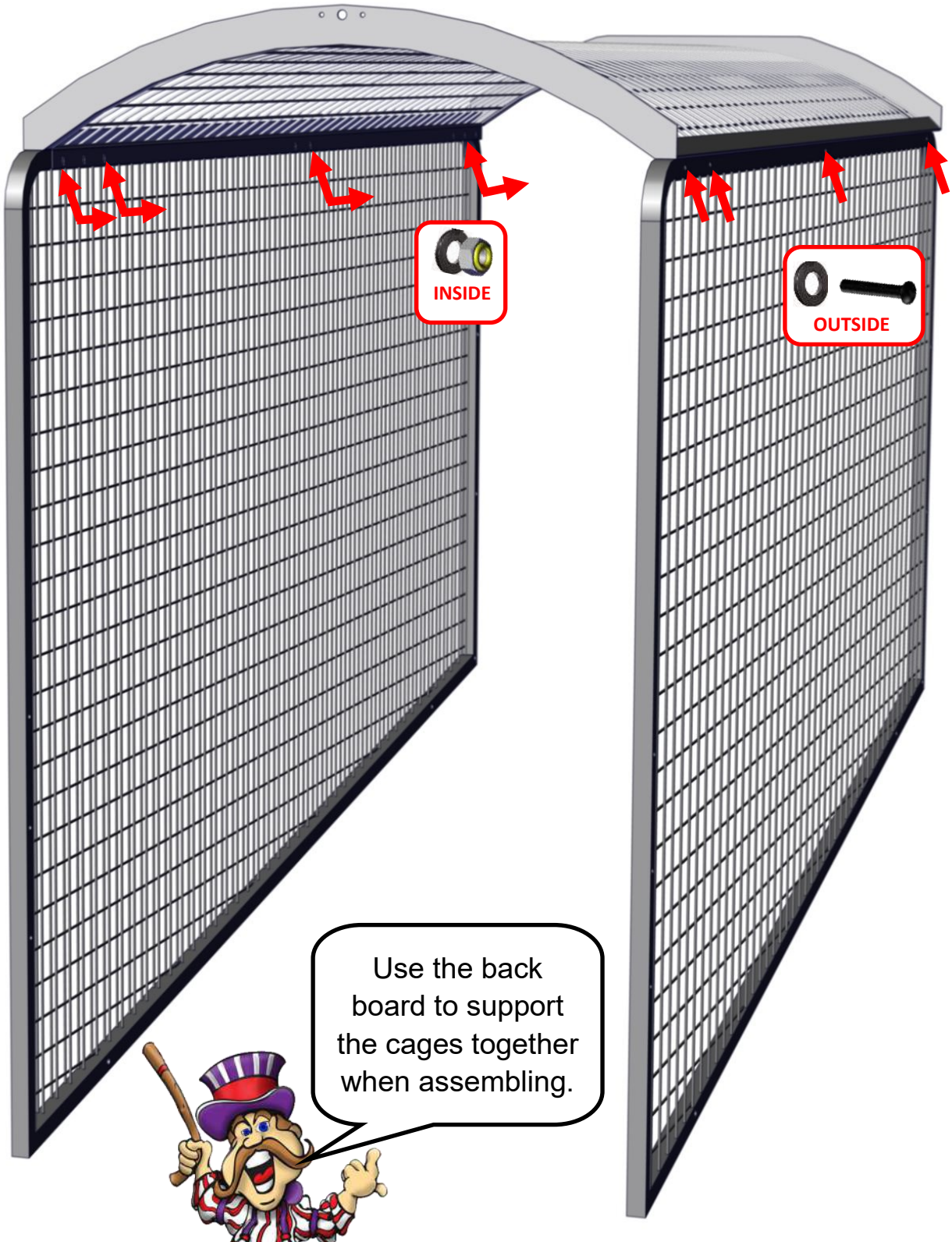

Step 5:

Lift cabinet upright onto the legs. The cabinet should be higher in the back.

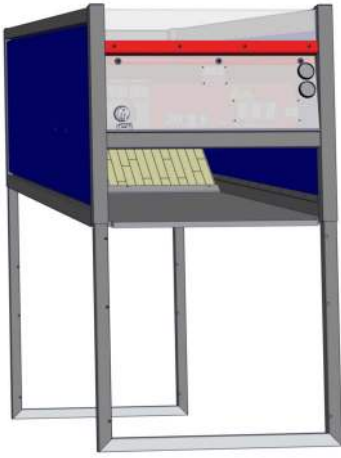

Step 6:

With one person on the inside of the cabinet and at least one person on each side of the cage, lift the cage assembly up and over the top of the cabinet. At each corner of the cage insert one joint connector (AA6110). Then on the inside secure the cage assembly at each corner with one AA6220 ¼-20 x 1¾" and AA6212 black washer.

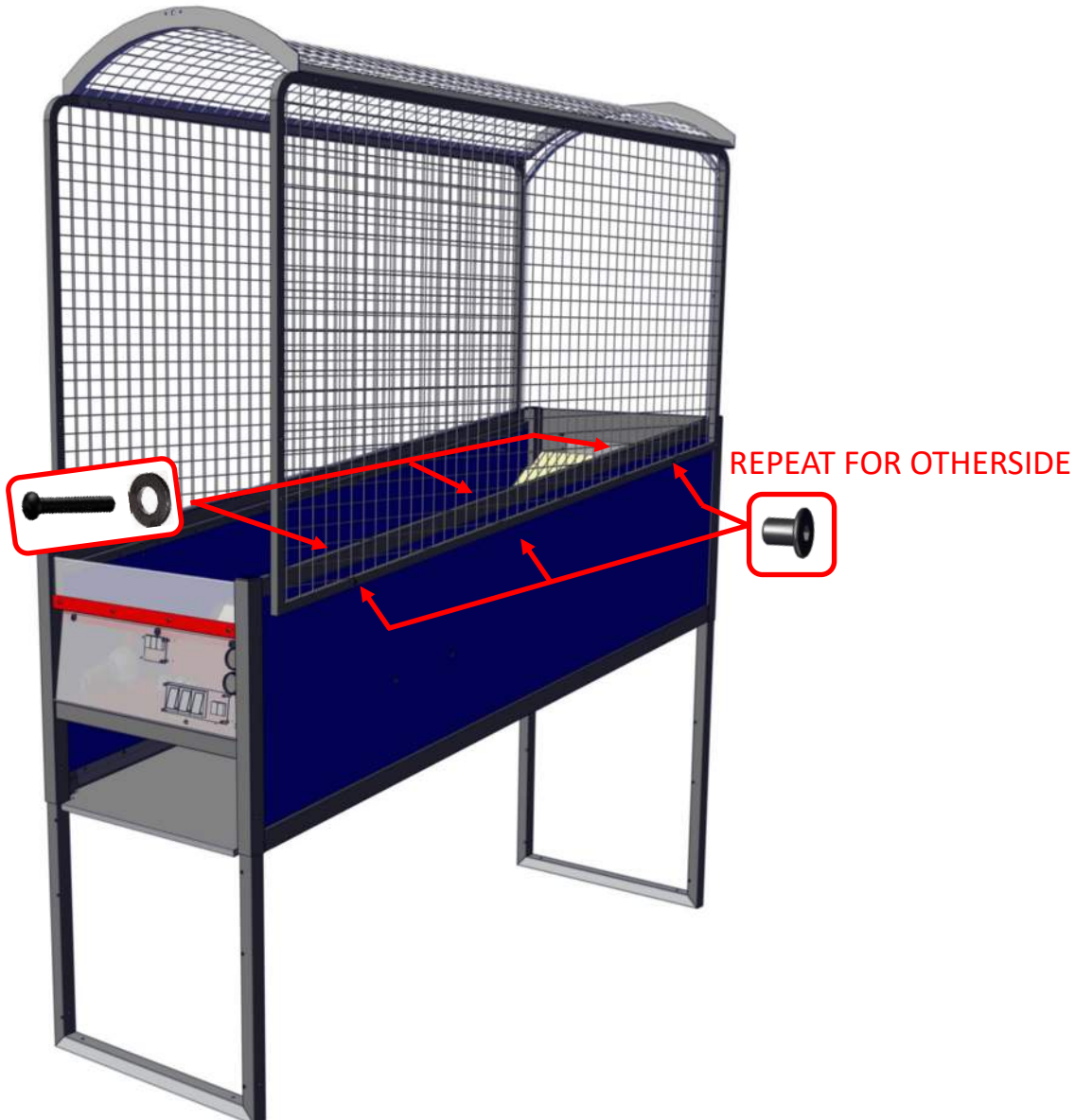

Step 7:

Lift the back board assembly up and slide the bottom notches over the side walls of the cabinet. The back board will slide into the cabinet's back. You might have to slightly tap the top of the back board until the sides mounting holes are centers and the top of the back board is flush to the bottom of the cage. The sides brackets go over the cage sides.

**** NOTE ****

Be careful not to crush the harnesses and earth ground connection!

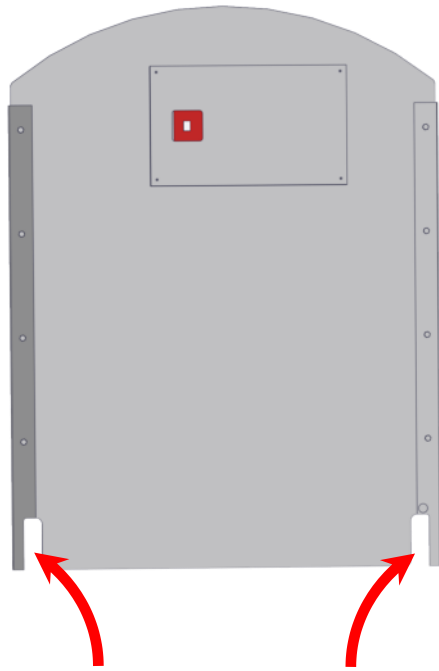

Notches for cabinet sides.

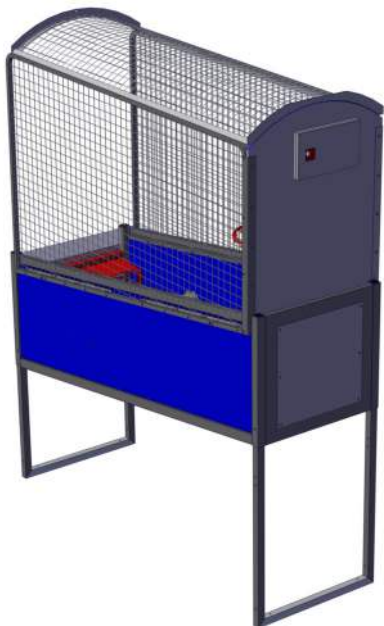
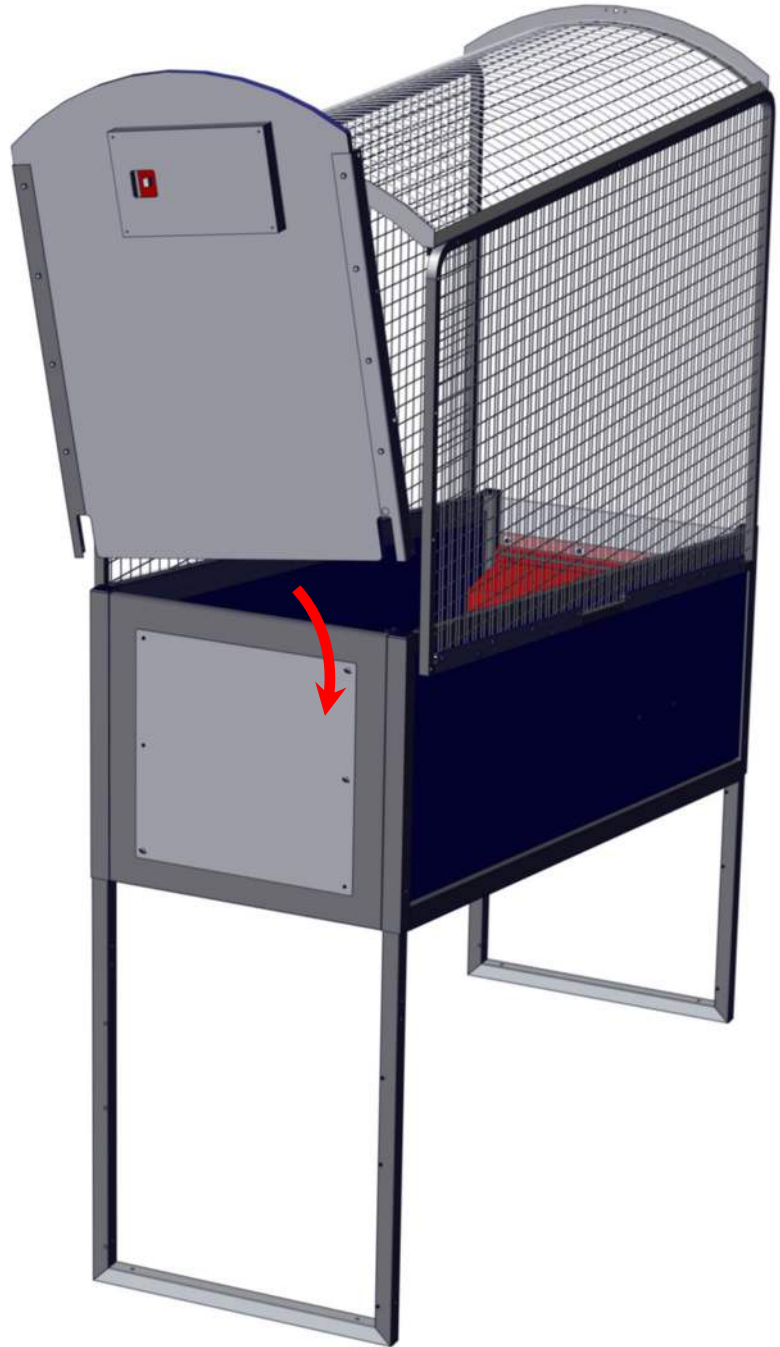

Step 8:

Secure the backboard by using four PC60601 ¼-20" x 1" Allen bolts and 6212 black washers.

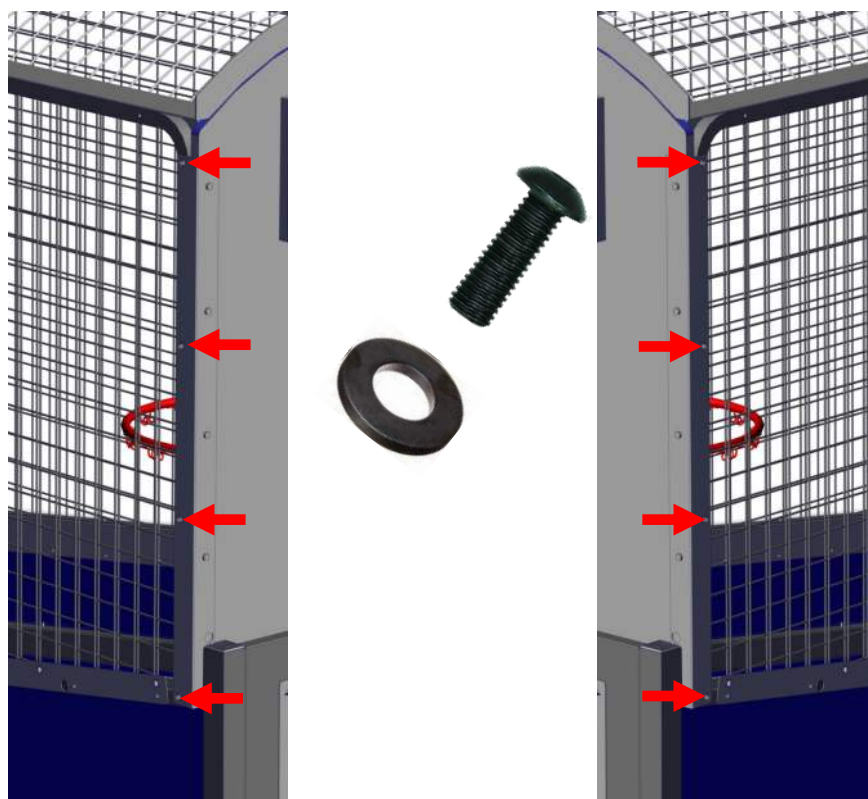

TIGHTEN ALL NUTS AND BOLTS AT THIS TIME!

Step 9

Locate the two LED harnesses and back board harness.

Plug them to their matting ends.

Connect the earth ground Lug to the backboard.

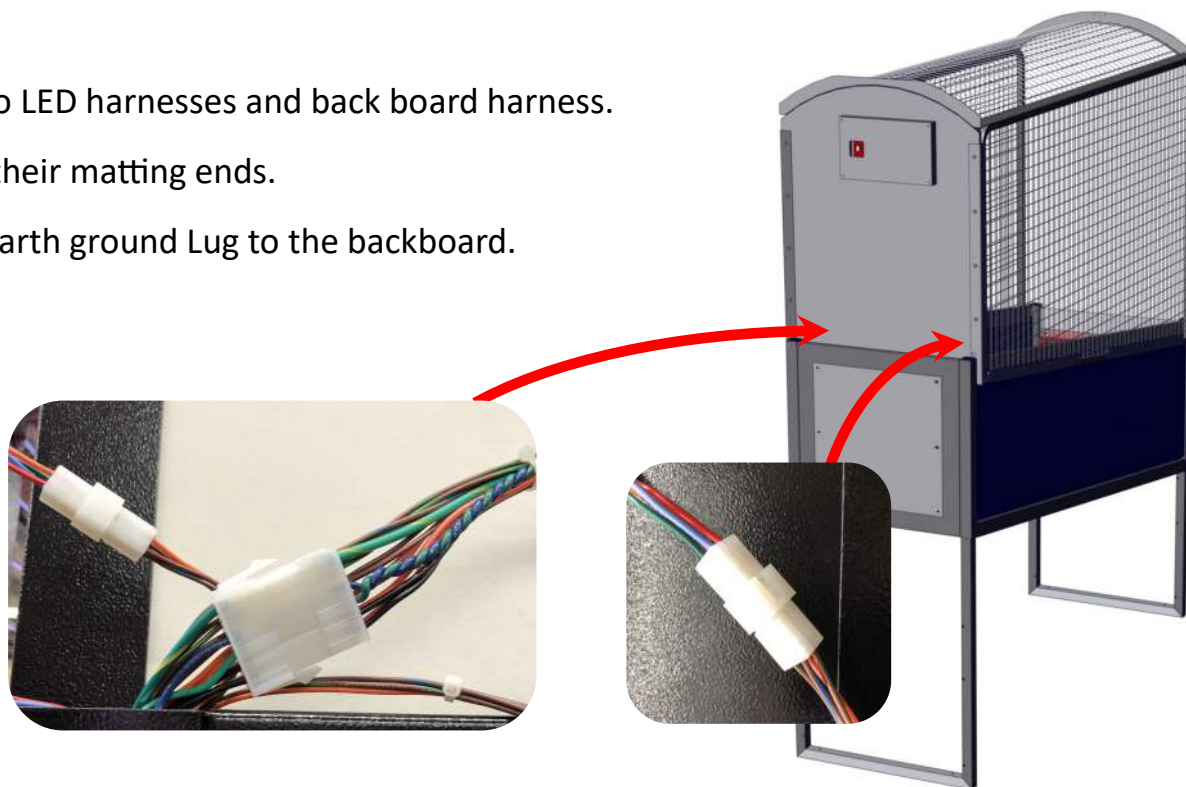

Step 10:

Attach the leg levers to the bottom of the podium.
Screw them half way into the mounting holes.

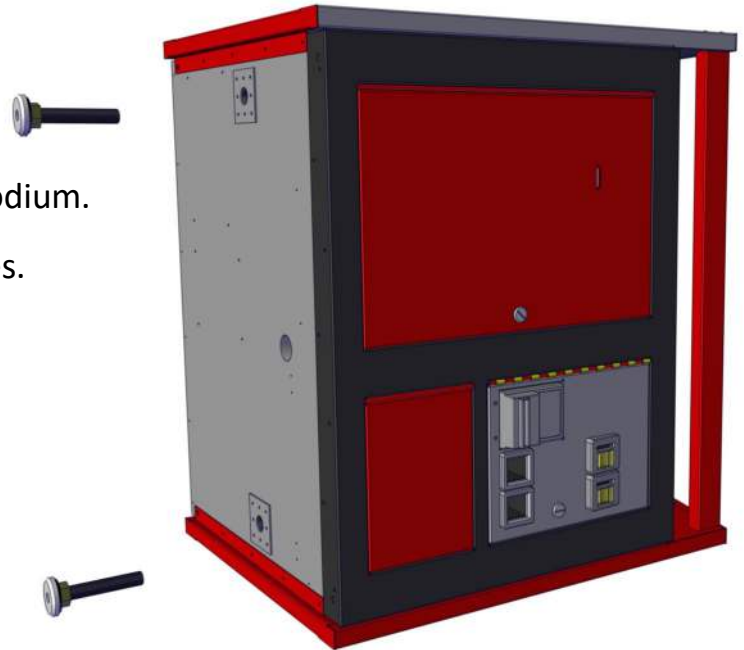

Step 11:

Attach the podium to the cabinet front legs using four AA6085 ¼-20 x 3½" 7/16 bolt head with AA6075 silver washer through the back legs. Inserts are located inside the podium.

DO NOT TIGHTEN AT THIS TIME!

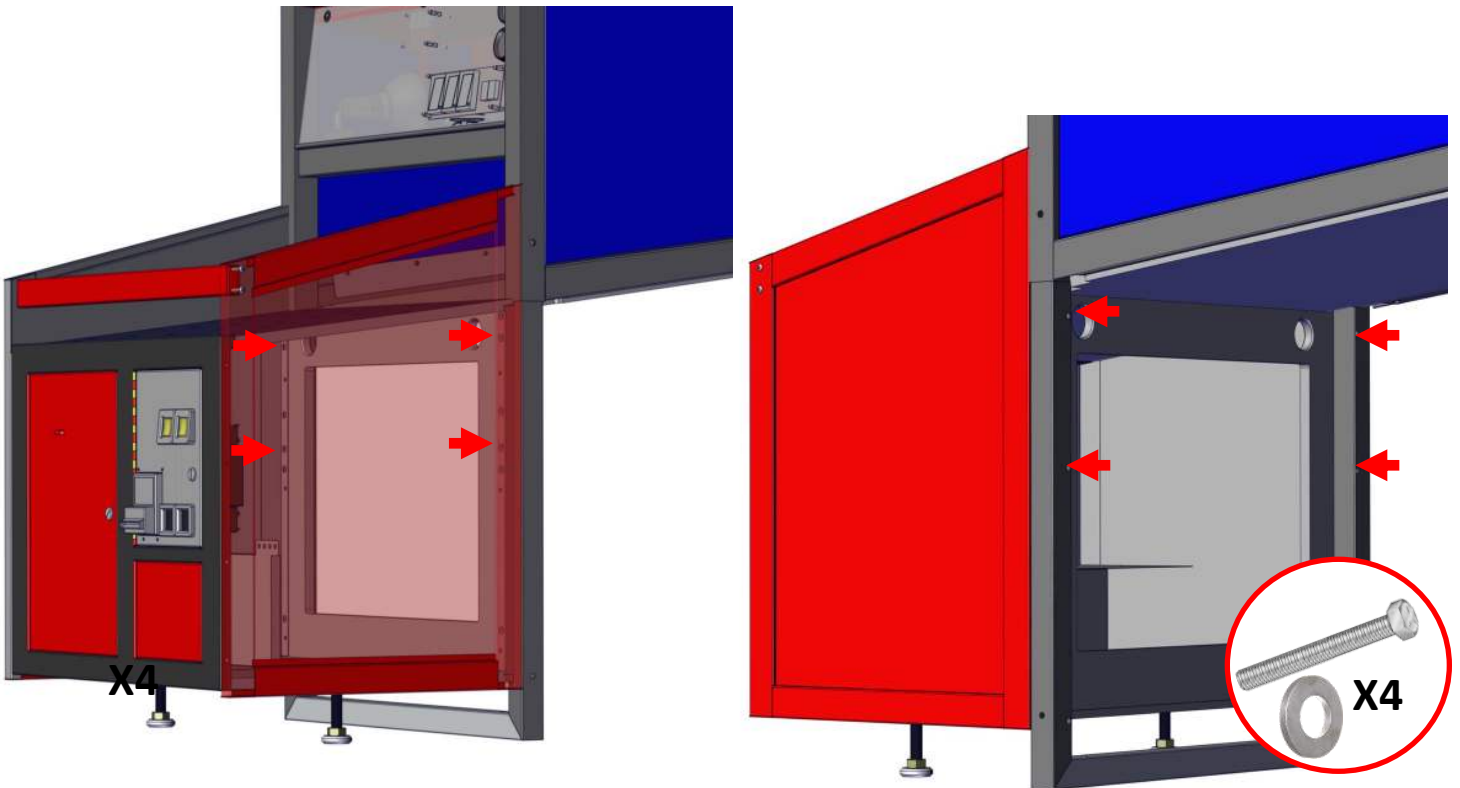

Step 12:

Position the front podium and adjust the lower leg levers so that the back cabinet is **FLUSH** and **LEVEL** with the front podium. **Once satisfied tighten all bolts.**

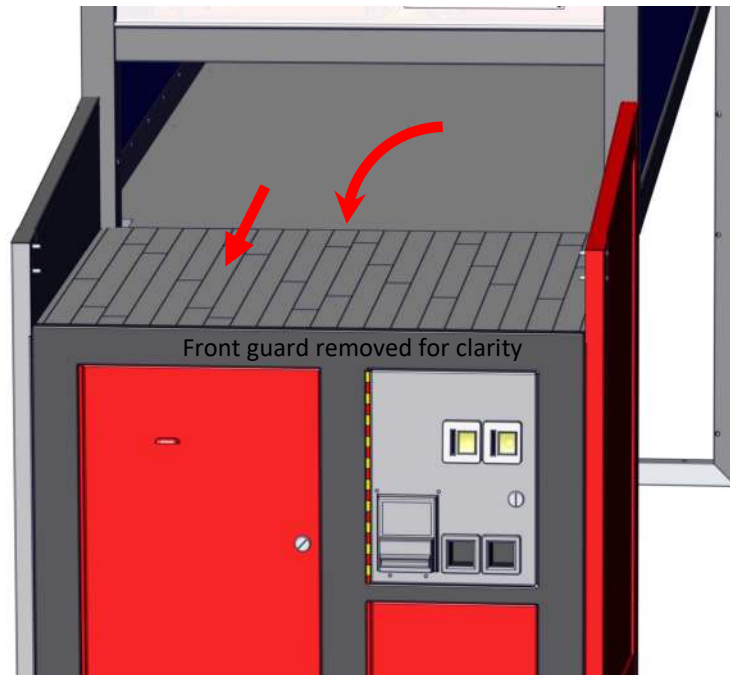

Harness Connection Steps.

Located at the back of the podium, right side, are the ball gate, AC, and back display harnesses. Push the wire harnesses through the back access hole. Then connect the three harnesses.

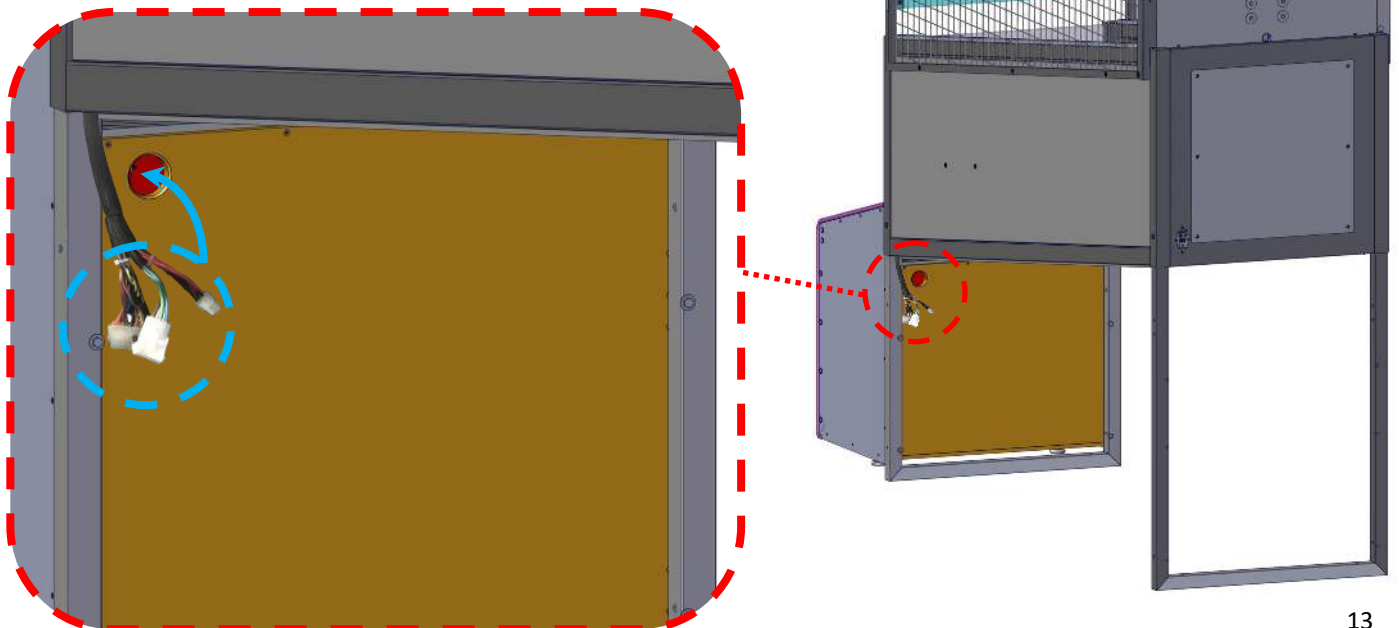

Harness Connection Steps continued.

Connect the harnesses together. Then zip tie them together as shown below. The zip tie will be mounted at the back wall.

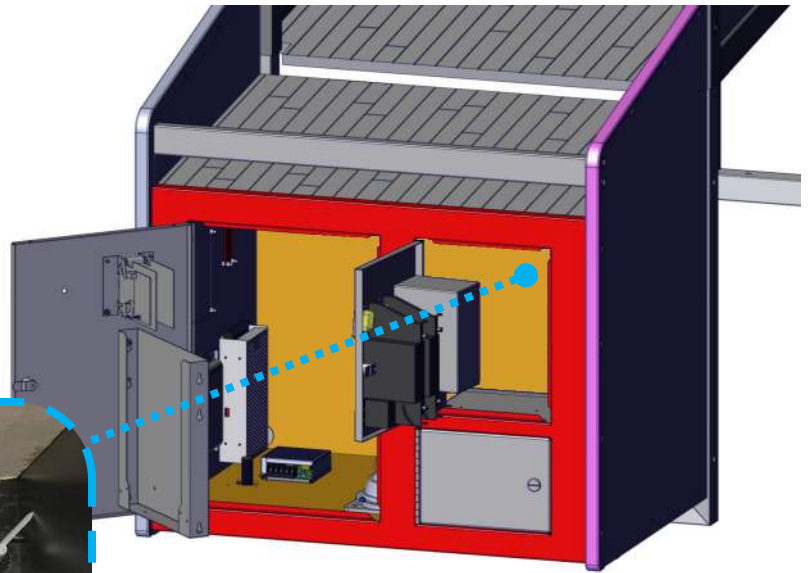
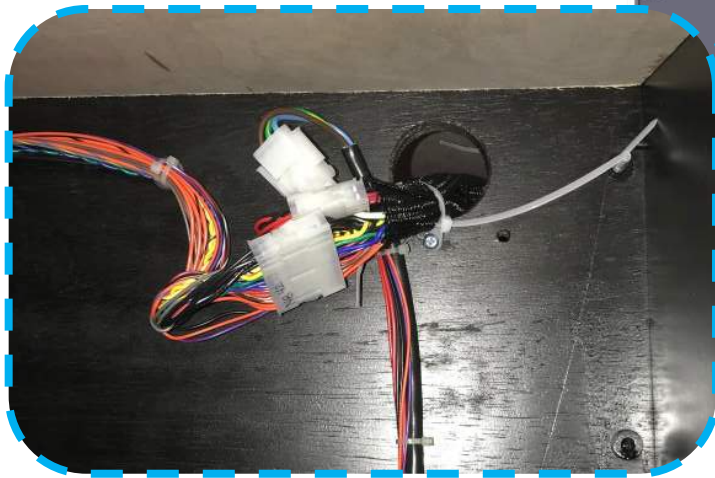

Step 13:

Attach one bracket on either side of the front cage using one AA6281 ¼-20 x 1½" with AA6212 washer through the outside and then secure it using AA6212 washer and PC60604 nylon nut.

DO NOT TIGHTEN AT THIS TIME!

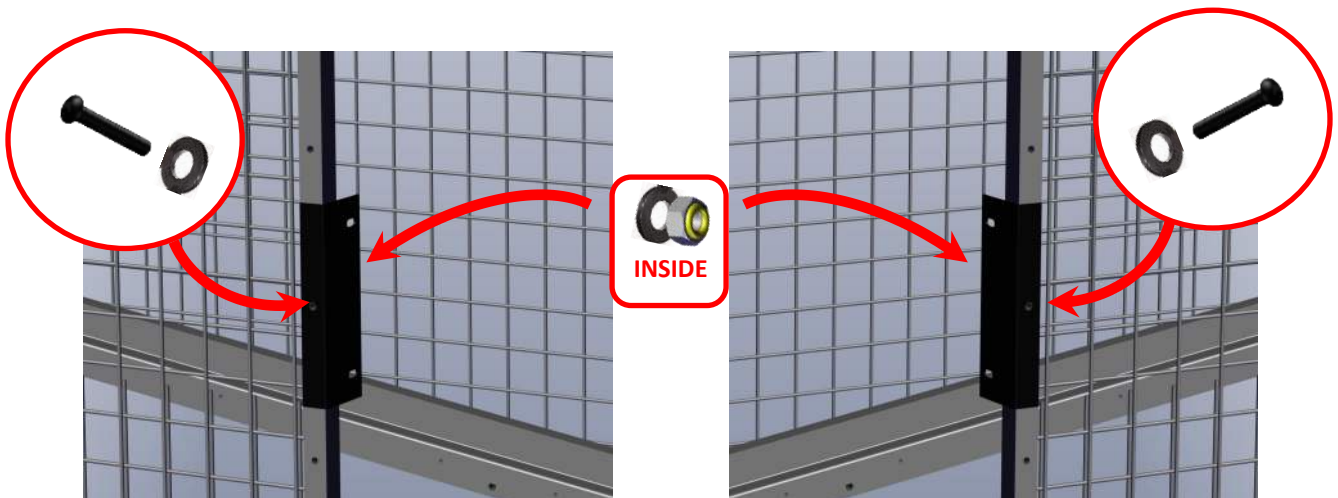

Step 14:

Attach the plastic rebound to the side brackets using four PC60622 with AA6212 washers and secure with four AA6212 washers and PC60604 nylon nuts.

It will be easier to stand on top of the podium while installing the hardware.

Tighten all hardware.

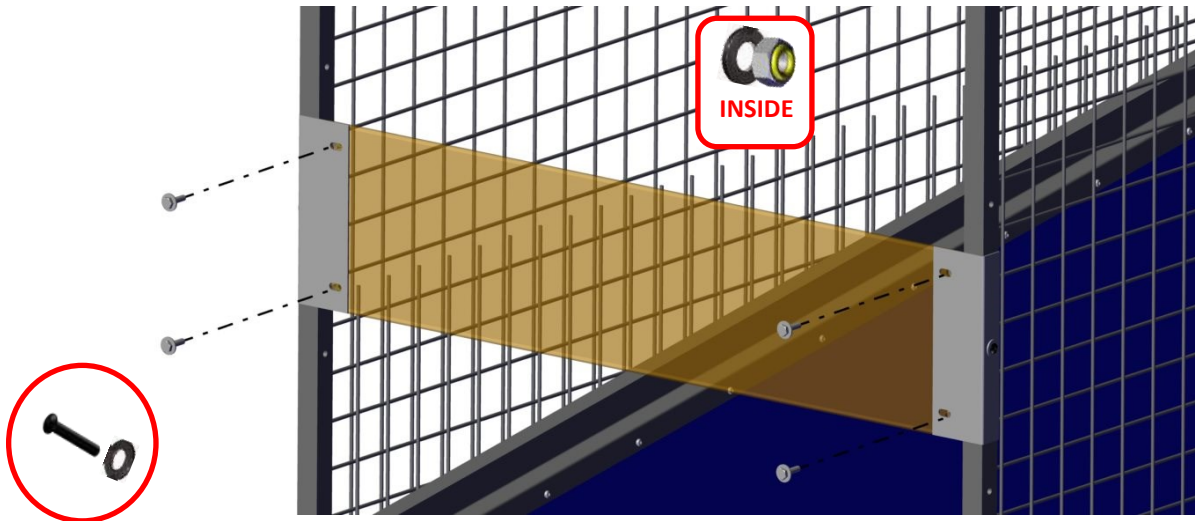

Skirt Install: Optional

Attach the bottom skirt to the inside of the legs using two AA6227 with AA6212 washers on the outside. Then secure them with two AA6110 joint connectors on the inside.

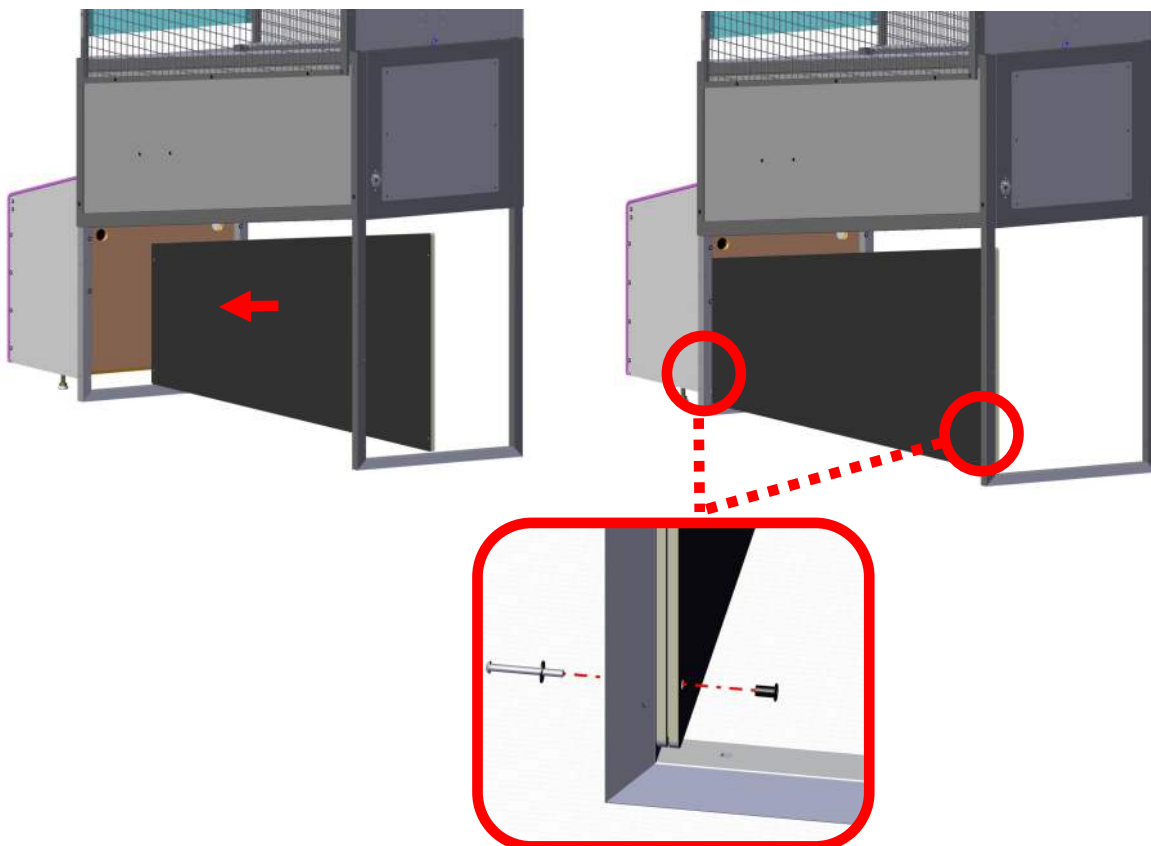

Attach the top skirt (NB3153) using two AA6458 security bolts, AA6212 washers, and secure with AA6110 joint connectors.

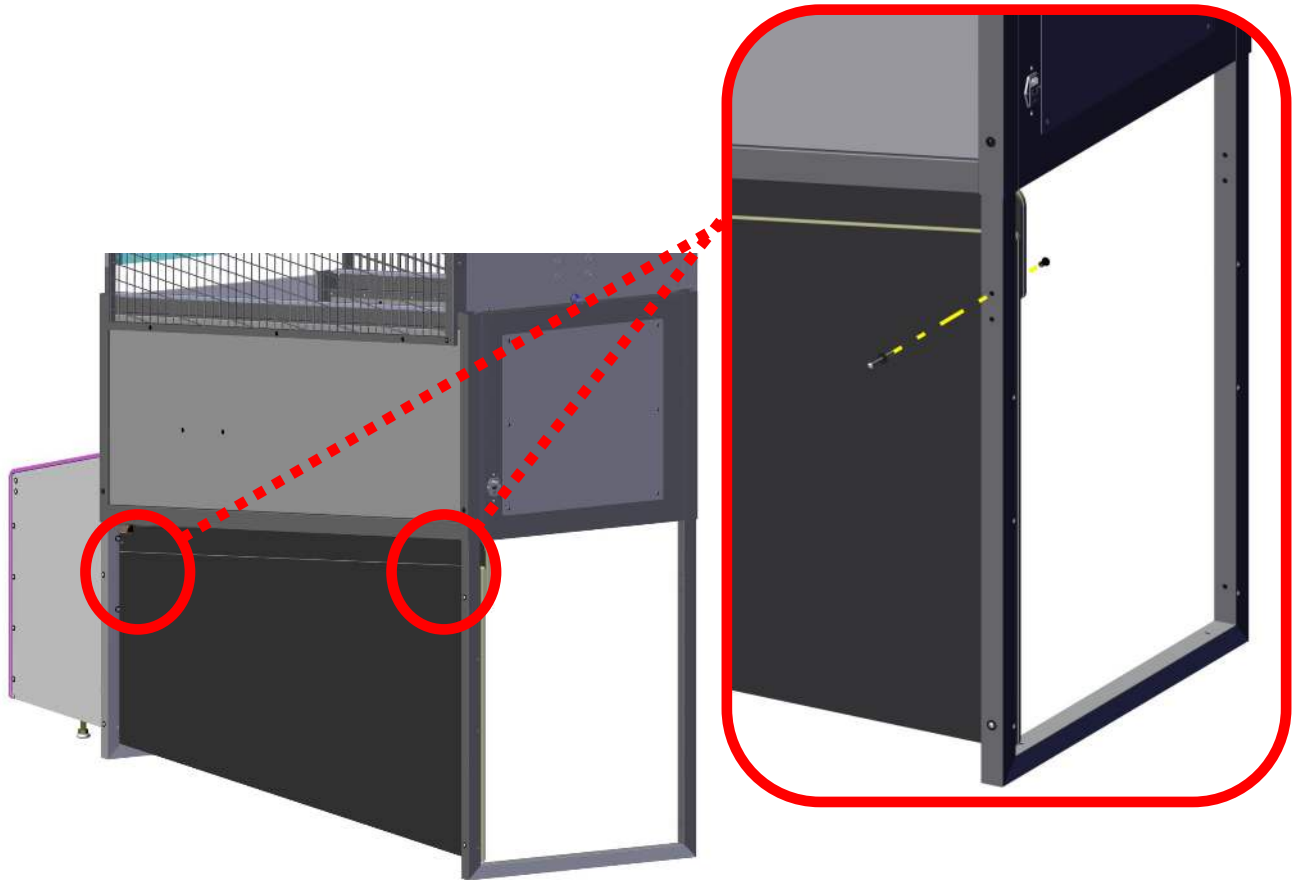

Repeat for the other side.

The upper skirt can be installed no matter which height is picked.

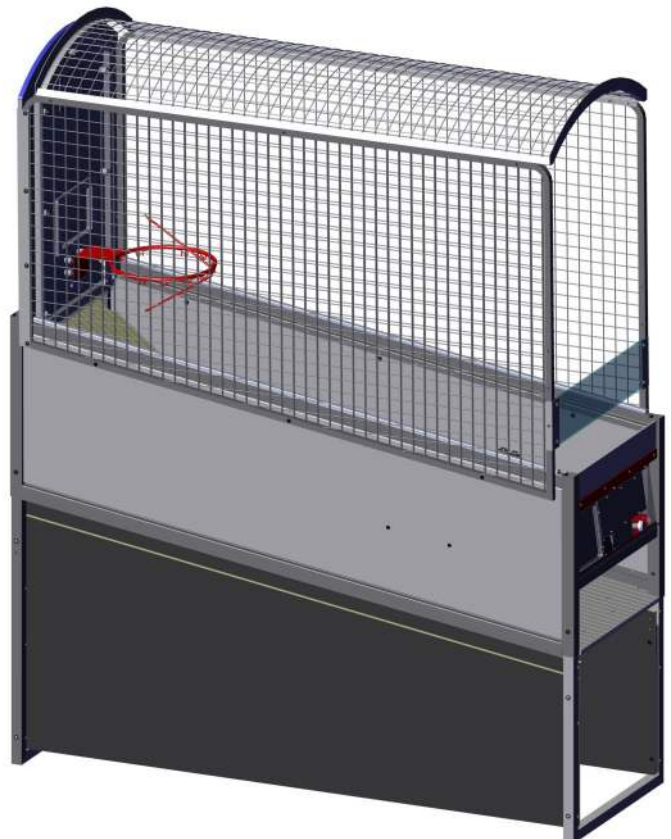

How to link your games.

To link two or more games together, connect one end of a RJ45 linking cable to the “OUT” (J5) jack of the first cabinet. Then connect the other end into the next game at “IN” (J4). Continue to connect cabinets this way until you get to the last cabinet. This cabinet you would connect a cable from the “out” (J5) to the “TERM” (J9) connector of the last cabinet.

No software options need to be changed in order to enable linking!

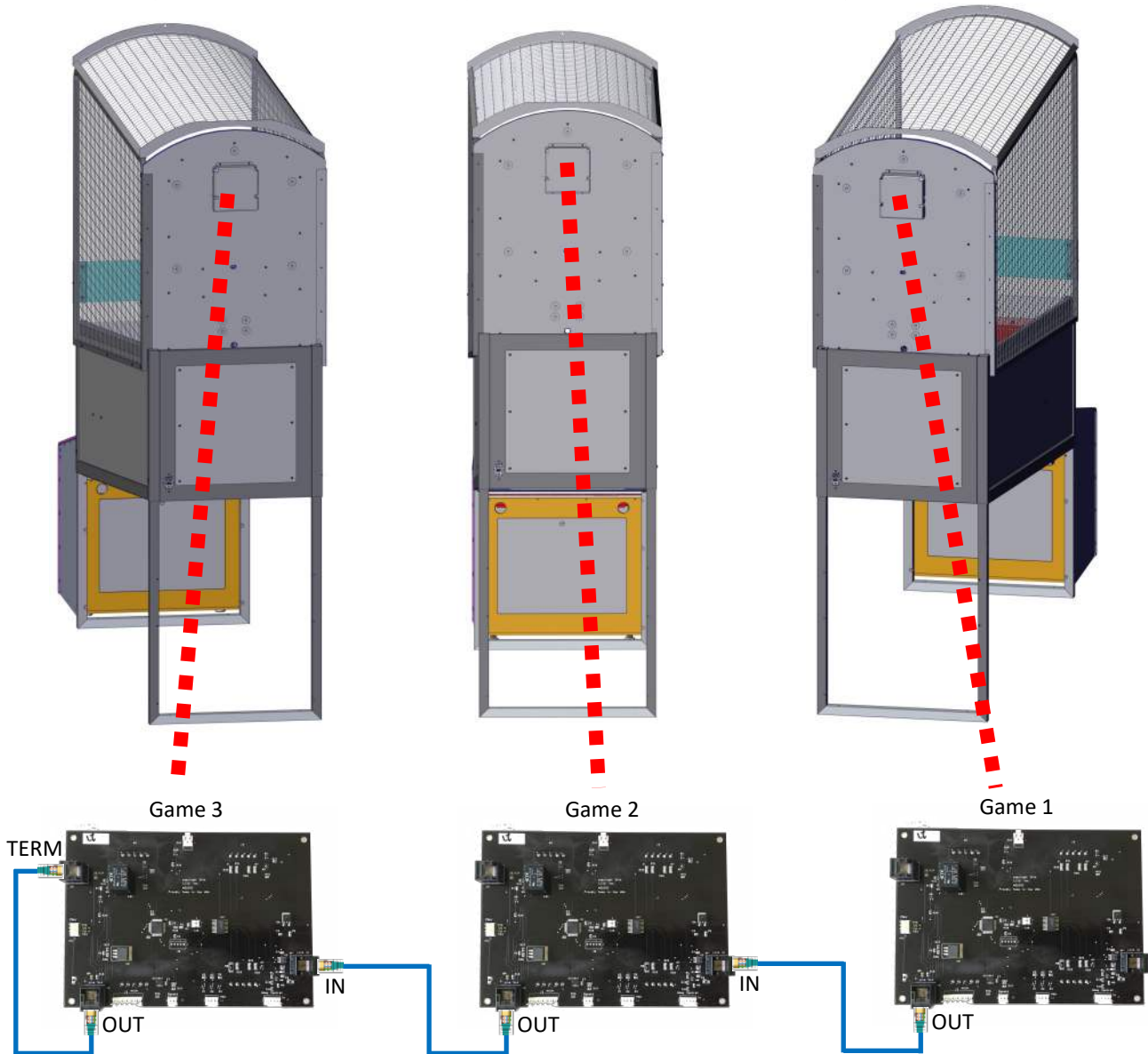

When power is applied, the game will display its version number on the back board, then pause, show it's assigned ID, then go into attract mode. If the game shows dashes instead of a assigned ID number, there was failed communication between the games. Double check connections go in to out and term is installed in last game.

NEVER MOVE GAMES WITH LINK CORD ATTACHED!

PROGRAMMING INSTRUCTIONS

Game options can be changed in program mode. The game must be in attract mode (no one playing the game) to enter program mode. Open the coin door to access the program button. Press the program button to enter program mode.

Pressing the “SELECT” button advances to the next option while pressing “UP” or “DOWN” buttons will change the value for that option. The high score will display the option number while the LED display will show the value for that option.

The next page details the options available and their meanings.

**NOTE: THIS IS A ONE PLAYER
GAME ONLY.**

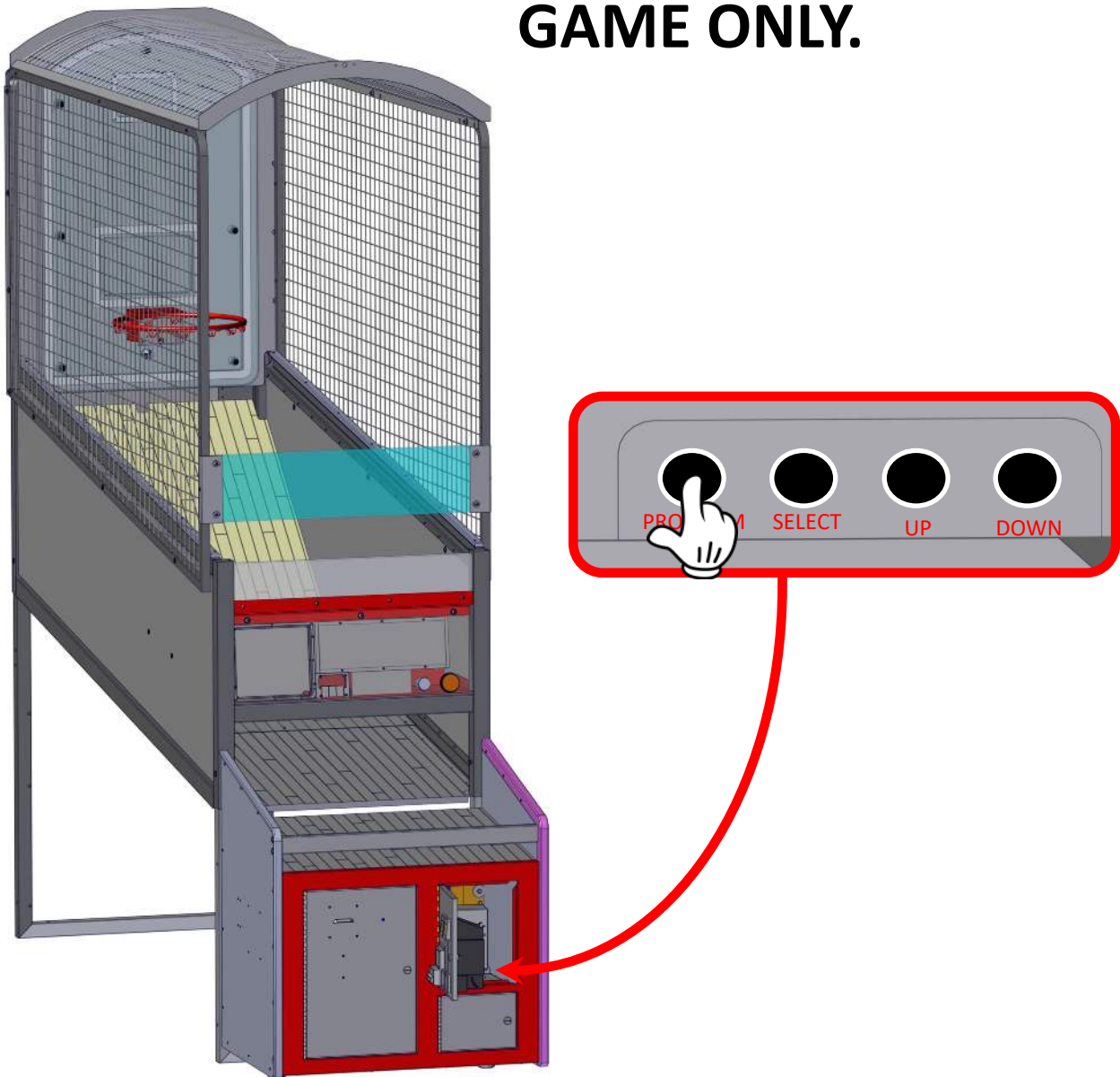

<u>Option</u>		<u>Default</u>	<u>Min</u>	<u>Max</u>	<u>Inc</u>	
0	Game Volume	5	0	7	1	"Game Volume"
<i>This option adjusts the volume levels for game commentaries and announcements.</i>						
1	Background Volume	6	0	7	1	"Background Volume"
<i>This option adjusts the volume of ambient noises and music.</i>						
2	Coin 1	1	0	9	1	"Cost of Credit"
<i>Defines how many pulses are needed to give one credit to start a game. A pulse can come from either the coin switch or dollar bill validator.</i>						
3	Coin 2	1	0	9	1	# of Coin 1's
<i>Coin line 2 wire is worth X many pulses of coin 1 pulses. For example a dollar coin is worth 4 quarters. If you attached a quarter to coin 1 wire and a dollar mech to coin 2 wire you would set this option to 4 because a dollar is worth four quarters (pulses).</i>						
4	DBV	4	0	9	1	# of Coin 1's
<i>DBV line is worth X many pulses of coin 1 pulse. Your DBV can be set in two ways. If the DBV is set to 4 then this option is set to 1. If your DBV is set to 1 then this option is set to 4.</i>						
5	Discount	0	0	9	1	"# of Games til Disc"
<i>When a value is other than 0 that many games purchased in a row (before starting a game) will result in one free game.</i>						
6	Games Per Credit	1	1	9	1	"# of Games Added per Credit"
<i>This option allows you to give more than one game per credit. For examples if this option is set to 2 and a player has purchased one credited, the game will give the player two games for that one credit.</i>						
7	Game Time	40	30	60	1	"Game in Seconds"
<i>The value of this option determines the total game time.</i>						
8	Attract Time	2	0	30	1	"Attract time"
<i>How many minutes should the attract mode should run. The type is set in option 7.</i>						
9	Ticket Divider	2	0	50	2	Ticket Divider (Points/Divider)
<i>This value is divided into the total amount of points earned to determine the amount of tickets to be paid. For example a value of 5 and the play scored 100 points at the end of the game, the game would pay 20 tickets out (if option 16 is set to 1).</i>						

10 JFP 0 0 20 1 Just for Playing Tickets

A value set here will pay this amount of tickets no matter how many points scored.

11 Link Time 10 0 10 1 How long to Wait for Link time

This option allows you to wait for this amount of time for other players to coin in before starting a game. (for linked games only).

12 High Score Ticket Bonus 500 0 2500 10 Bonus Tickets

This option sets how many tickets will be paid out if the high score is achieved.

13 Default High Score 75 50 250 1 Default High Score/ Not saved

This option sets the high score on power up.

14 Save High Score 0 0 1 1 1 = Save, 0 = No Save

This option tells the game to remember the high score or not.

15 Ticket Cap 0 0 50 1 Max Tickets Given per game, 0 = off

This option will limit the total amount of tickets that can be paid.

16 Ticket Multiplier 1 0 2 1 0-JFF/Free, 1-Normal, 2-1/2 physical

This option allows you to turn off tickets or divide the amount of tickets owned in half. Leaving the value on 1 will pay out 1 ticket owed = 1 ticket paid. When set to 1 or 2 options 10 and 15 are used. When both 16 and 10 are 0 and 15 is 1 the game will give a free game instead of tickets. If 16 and 15 are 0 but 10 has a value, those tickets will be paid no matter what the player scores. If 16,10, and 15 are 0 then the game is in just for fun mode and no tickets will be paid.

17 3 Point Time 10 0 30 1 3 Point time left start time

This option sets the length of time the game will award 3 points instead of 2 at the end of the game. It will not add additional time to the game play.

18 Bonus Round Time 15 10 60 1 Bonus Round Length

This value sets the length of time for the bonus round. This is in addition to the game time. The player must score at least the value stored in option 19 to be able to play the bonus round.

19 Bonus Round Target 50 0 200 2 Target Score for Bonus Round

This is the amount of points needed to play the bonus round at the end of the game. Note, if games are linked, each player will be allowed to play the bonus round regardless of points won if one player achieves the score.

20 Bonus Round Points 1 1 3 1 Points per Basket Bonus Round

This option allows you to set the amount of points for each basket during the bonus round.

HOW TO ENTER MARQUEE PROGRAM MODE FOR NEW NBA

The game must be in attract mode and not be being played. From the front of the game open the upper coin door and press the “DOWN” button. The Marquee will display P0 and a value. The marquee is showing the first option and its programmed value.

Pressing the “SELECT” button will cycle through the options.

Pressing the “UP” button will increase the current value for that option.

Pressing the “DOWN” button will decrease the current value for that option.

To exit and save settings, press the “PROGRAM” button. If you press the “PROGRAM” button again, it will enter the game’s programming mode and not the marquee programming mode.

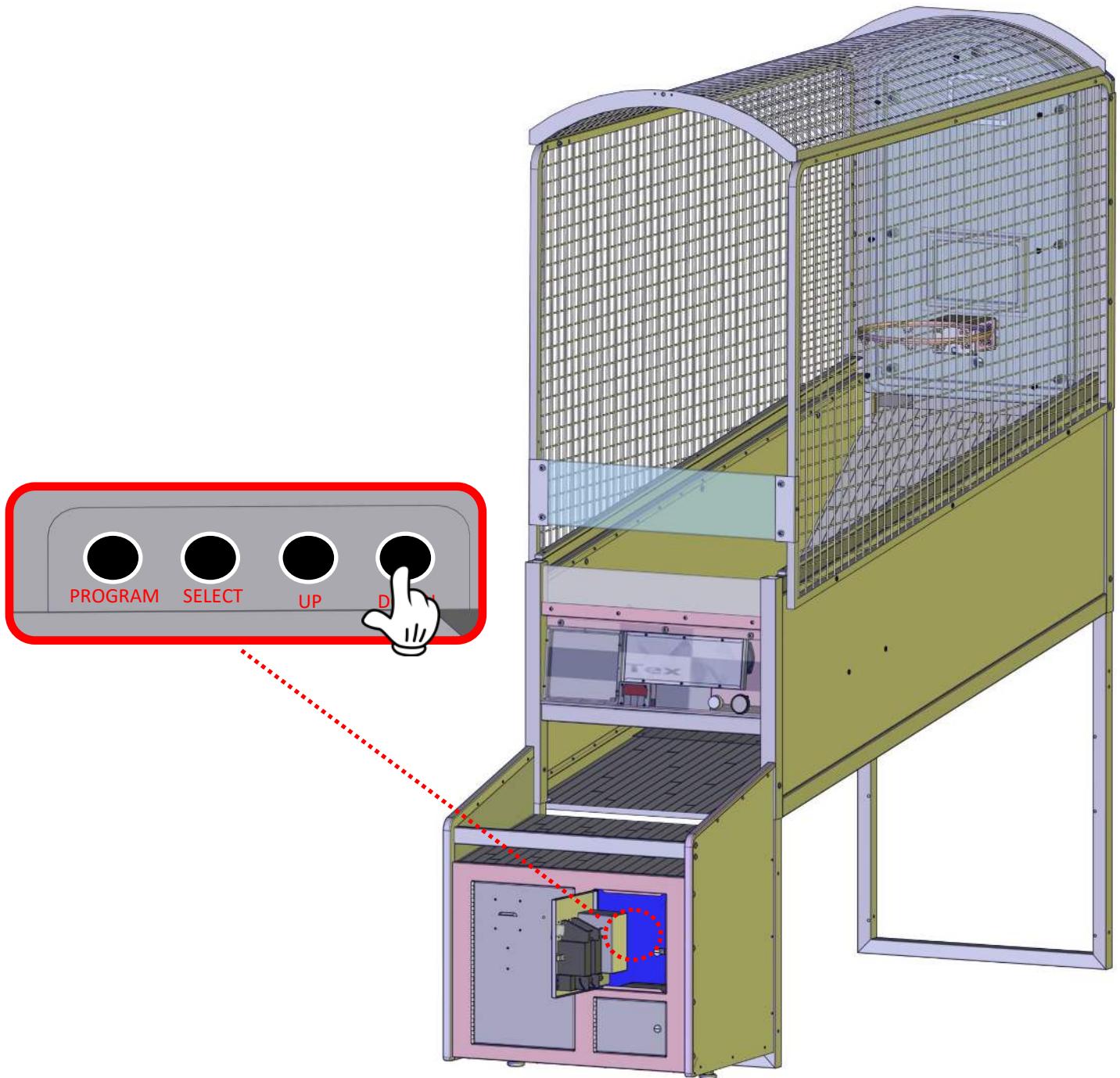

Programming Options for NBA Marquee New

<u>Option</u>		<u>Default</u>	<u>Min</u>	<u>Max</u>	<u>Inc</u>	
0	Score Base	75	25	250	1	Lowest Score
1	Ticket Base	100	0	9975	25	Tickets for High Score
2	Games To Dec	5	0	100	1	How many Lost games to Dec Score
3	Dec Amount	5	1	20	1	When Dec change by this amount
4	Games to Inc Tickets	1	0	100	1	Game losses to Inc Tickets
5	Inc Amount	1	1	20	1	How many Tickets when Inc'd
6	Save High Score	0	0	1	1	High Score remains for power cycle
7	Color 1	0	0	7	1	Color 1
8	Color 2	4	0	7	1	Color 2
9	Color 3	2	1	7	1	Color 3
10	Color Speed	5	0	20	1	Speed of Color Cycle

Selected Color Numbers For both Versions

Color 0 Red

Color 1 White

Color 2 Blue

Color 3 Orange

Color 4 Green

Color 5 Yellow

Color 6 Pink

Color 7 Purple

Note:

To enter programming mode you must be on linked game #1. Press the DN button to enter programming mode. You cannot be in game programming mode to do this. After that the Marquee will show a P0 and a value. That is option #0. Pressing the select button will cycle thru the modes. Pressing the up button will increment the option wrapping if you go to far. Pressing the dn button will decrement the option, again wrapping if you go to low.

To exit MQ programming press the prg button. Doing this once will exit programming of the marquee and pressing it again will enter programming for the game.

OPERATIONAL BACKGROUND

The following will outline the basic operating principles of the NBA HOOPS™ basketball game. The ball gate uses micro switches to determine positioning of the gate, which are activated by the cam on the ball gate shaft.

The gear motor uses a combination of hardware and software control to protect against over current damage. When an over current condition is detected, the motor will shut off automatically. The game microprocessor will then decide whether or not the motor should be turned on. It will also determine at that time which way the motor should run.

GENERAL CLEANING

Clean the surfaces of the cabinet and decals with a commercial cleaner such as 409™ or Fantastic™. Do NOT use cleaners such as Wildcat pinball cleaner or alcohol. It can take the finish off of the decals. Use Pledge™ on all plastic and painted surfaces. This product works especially well on clear plastics. Please note that other spray polishes do not work as well.

BASKETBALLS

The basketballs should be checked every week for proper inflation. A bicycle tire pump and inflating needle can be purchased at any sporting goods store and most large discount stores. Keeping the balls properly inflated will make it more difficult to pull them past the ball gate. It will also create more realistic basketball action when interacting with the hoop.

Any 8" basketball will work with this game.

NOTE: DO NOT OVER-INFLATE THE BASKETBALLS. THIS CAN CAUSE DAMAGE TO THE BALL AND SHORTEN THE LIFE OF THE BALLS.

BALL GATE Removal:

- Remove AC power
- Unfasten the (6) square drive screws and remove the ball gate housing, located on the right hand side of the ball gate assembly.
- Unbolt the control panel from the front of the game to gain access to the control panel.
- Unplug the two mate-lock connectors (2 pin connector with the yellow/black and brown/white wires and the three pin connector with the red, black and blue wires) located to the right of the transformer. Cut any tie-wraps holding the harnessing.
- Remove the two bolts that hold the ball gate bearing in place, located on the left hand side of the assembly. (Hint: a long extension on a ratchet can be helpful for this operation.)
- Pull the ball gate from the end by the bearing towards you. (the front of the game)
- The gear motor can now be pulled away from the retaining bracket.
- Remove the two Allen head set screws to remove the ball gate from the gear motor.
- NOTE: When removing wires from the micro switches or motor, it is VERY important to make sure all wires are returned to their proper terminals. Failure to do so will result in improper operation of the ball gate and could damage the game. The wires are color coded so it will be easy to document where each wire goes.
- IMPORTANT: Mark the position of the micro switch mounting bracket so that the switch actuators will line up correctly with the cam on the ball gate when the unit is re-assembled.
- Use thread locking compound on the Allen head set screws when re-assembling the ball gate to the gear motor.
- Assemble in reverse order of disassembly. Tighten all hardware securely.
- Re-test for proper operation
- Temporarily shut off AC power, reconnect battery and turn AC power back on.

GAME TROUBLESHOOTING FLOWCHART V2.0

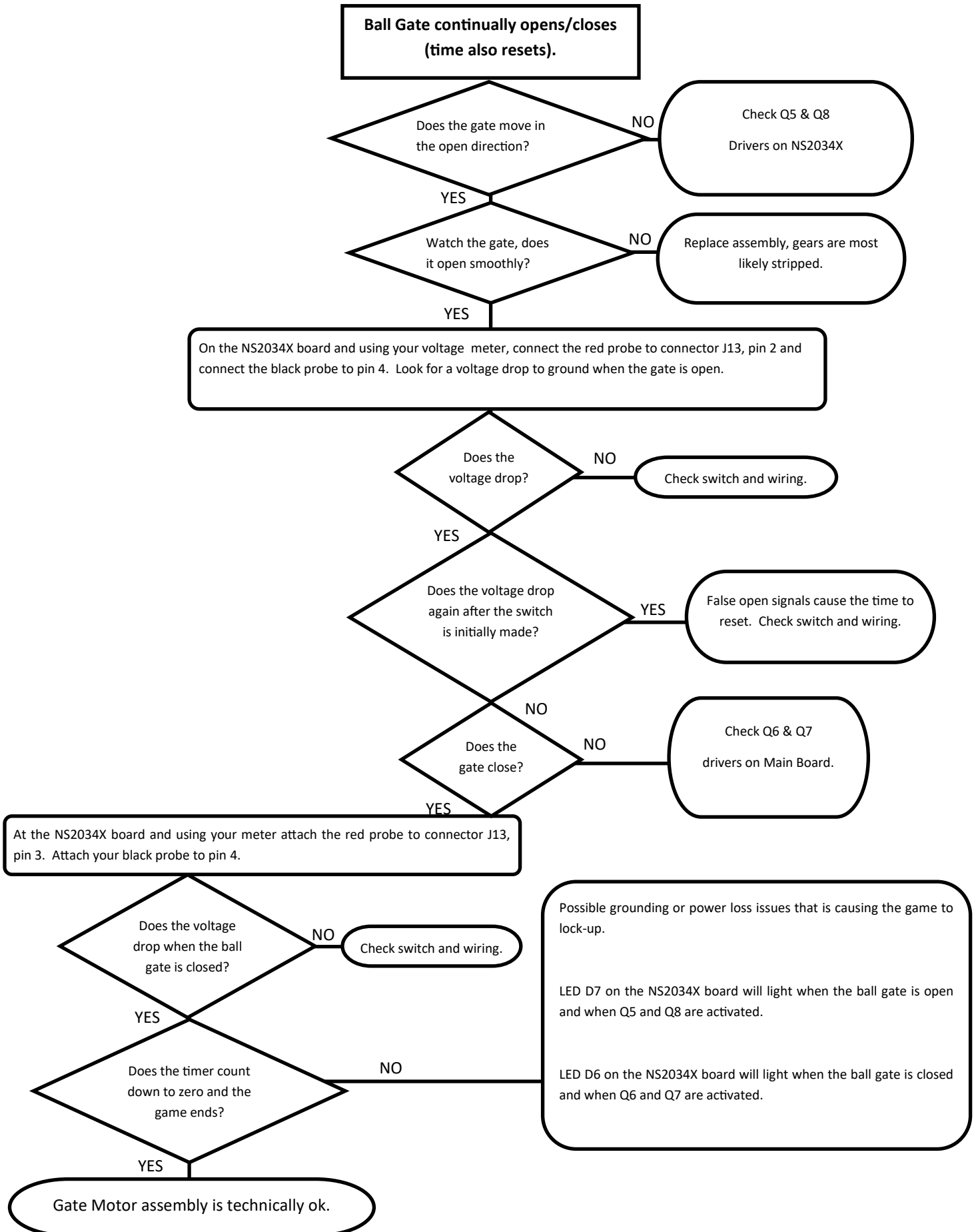

DOLLAR BILL VALIDATOR

The NBA Hoops game comes pre wired for a 120VAC Mei bill acceptor. The 9 pin interface connector is located in the lower cabinet and is zip tied back with the coin harnessing if the game was not purchased from ICE with a dollar bill validator installed. For the game to properly accept credits you must use the "coupon" programming mode for the validator.

COUPON CONFIGURATION (ALL SWITCHES OFF)

Download a coupon from an AE2600 Installation Guide. Copies are usable if made on a standard, carbon-based, non-color copier, AND if cut to match the size of the attached coupon.

Fill out the coupon using a #2 or HB pencil. Fill in one block for each line. Do not mark the back Of the coupon.

Section 1 - Bill Direction Enable one or two-way (face-up) or four-way acceptance (all directions).Your choice.

Section 2 - Bill Denomination Fill in one block for each denomination. Your choice.

Select High Accept for maximum bill acceptance.

Select High Security for a higher level of discrimination.

Select OFF to reject bills of that denomination.

Section 3 – Pulse Timing Select LONG.

Section 4 – Pulses per Dollar use FOUR PULSES.

Section 5 – ON

Once you have filled out the coupon, Locate the service button on the back of the unit and depress the button once to enter coupon set-up mode. Depressing again will exit the mode. Insert coupon and verify settings were accepted.

ACCEPTED: Coupon returned immediately and LED flashes 10 times when coupon pulled out.

REJECTED: Coupon returned after ten seconds. LED flashes number of times corresponding to section improperly filled out.

Example: Five flashes for improper section five. If rejected, review instructions or try new coupon.

<p>Insert this end first ←</p> <p>USE #2 Pencil Photocopy can be used</p>	<p>Complete sections 1-5 ONLY</p>	<p>7</p>	<p>1</p>	<p>2</p>	<p>3</p>	<p>4</p>	<p>5</p>	<p>6</p>
		<input type="checkbox"/> 1 <input type="checkbox"/> 2 <input type="checkbox"/> 4	<p># Of Bill Directions</p>	<p>High Accept</p> <input type="checkbox"/>	<p>Short</p> <input type="checkbox"/>	<p>Long</p> <input type="checkbox"/>	<p>1</p> <input type="checkbox"/>	<p>2</p> <input type="checkbox"/>
		<p>High Security</p> <input type="checkbox"/>	<p>\$1</p> <input type="checkbox"/>	<p>OFF</p> <input type="checkbox"/>	<p>Credit Line</p> <input type="checkbox"/>	<p>3</p> <input type="checkbox"/>	<p>4</p> <input type="checkbox"/>	<p>On</p> <input type="checkbox"/>
		<p>OFF</p> <input type="checkbox"/>	<p>\$2</p> <input type="checkbox"/>	<p>OFF</p> <input type="checkbox"/>	<p>4</p> <input type="checkbox"/>	<p>1</p> <input type="checkbox"/>	<p>2</p> <input type="checkbox"/>	<p>Off</p> <input type="checkbox"/>
		<p>OFF</p> <input type="checkbox"/>	<p>\$5</p> <input type="checkbox"/>	<p>OFF</p> <input type="checkbox"/>	<p>4</p> <input type="checkbox"/>	<p>3</p> <input type="checkbox"/>	<p>4</p> <input type="checkbox"/>	<p>F</p> <input type="checkbox"/>
		<p>OFF</p> <input type="checkbox"/>						<p>On</p> <input type="checkbox"/>
								<p>Off</p> <input type="checkbox"/>
								<p>On</p> <input type="checkbox"/>
								<p>Off</p> <input type="checkbox"/>
								<p>On</p> <input type="checkbox"/>
								<p>Off</p> <input type="checkbox"/>
								<p>On</p> <input type="checkbox"/>
								<p>Off</p> <input type="checkbox"/>
								<p>On</p> <input type="checkbox"/>
								<p>Off</p> <input type="checkbox"/>
								<p>On</p> <input type="checkbox"/>
								<p>Off</p> <input type="checkbox"/>
								<p>On</p> <input type="checkbox"/>
								<p>Off</p> <input type="checkbox"/>
								<p>On</p> <input type="checkbox"/>
								<p>Off</p> <input type="checkbox"/>
								<p>On</p> <input type="checkbox"/>
								<p>Off</p> <input type="checkbox"/>
								<p>On</p> <input type="checkbox"/>
								<p>Off</p> <input type="checkbox"/>
								<p>On</p> <input type="checkbox"/>
								<p>Off</p> <input type="checkbox"/>
								<p>On</p> <input type="checkbox"/>
								<p>Off</p> <input type="checkbox"/>
								<p>On</p> <input type="checkbox"/>
								<p>Off</p> <input type="checkbox"/>
								<p>On</p> <input type="checkbox"/>
								<p>Off</p> <input type="checkbox"/>
								<p>On</p> <input type="checkbox"/>
								<p>Off</p> <input type="checkbox"/>
								<p>On</p> <input type="checkbox"/>
								<p>Off</p> <input type="checkbox"/>
								<p>On</p> <input type="checkbox"/>
								<p>Off</p> <input type="checkbox"/>
								<p>On</p> <input type="checkbox"/>
								<p>Off</p> <input type="checkbox"/>
								<p>On</p> <input type="checkbox"/>
								<p>Off</p> <input type="checkbox"/>
								<p>On</p> <input type="checkbox"/>
								<p>Off</p> <input type="checkbox"/>
								<p>On</p> <input type="checkbox"/>
								<p>Off</p> <input type="checkbox"/>
								<p>On</p> <input type="checkbox"/>
								<p>Off</p> <input type="checkbox"/>
								<p>On</p> <input type="checkbox"/>
								<p>Off</p> <input type="checkbox"/>
								<p>On</p> <input type="checkbox"/>
								<p>Off</p> <input type="checkbox"/>
								<p>On</p> <input type="checkbox"/>
								<p>Off</p> <input type="checkbox"/>
								<p>On</p> <input type="checkbox"/>
								<p>Off</p> <input type="checkbox"/>
								<p>On</p> <input type="checkbox"/>
								<p>Off</p> <input type="checkbox"/>
								<p>On</p> <input type="checkbox"/>
								<p>Off</p> <input type="checkbox"/>
								<p>On</p> <input type="checkbox"/>
								<p>Off</p> <input type="checkbox"/>
								<p>On</p> <input type="checkbox"/>
								<p>Off</p> <input type="checkbox"/>
								<p>On</p> <input type="checkbox"/>
								<p>Off</p> <input type="checkbox"/>
								<p>On</p> <input type="checkbox"/>
								<p>Off</p> <input type="checkbox"/>
								<p>On</p> <input type="checkbox"/>
								<p>Off</p> <input type="checkbox"/>
								<p>On</p> <input type="checkbox"/>
								<p>Off</p> <input type="checkbox"/>
								<p>On</p> <input type="checkbox"/>
								<p>Off</p> <input type="checkbox"/>
								<p>On</p> <input type="checkbox"/>
								<p>Off</p> <input type="checkbox"/>
								<p>On</p> <input type="checkbox"/>
								<p>Off</p> <input type="checkbox"/>
								<p>On</p> <input type="checkbox"/>
								<p>Off</p> <input type="checkbox"/>
								<p>On</p> <input type="checkbox"/>
								<p>Off</p> <input type="checkbox"/>
								<p>On</p> <input type="checkbox"/>
								<p>Off</p> <input type="checkbox"/>
								<p>On</p> <input type="checkbox"/>
								<p>Off</p> <input type="checkbox"/>
								<p>On</p> <input type="checkbox"/>
								<p>Off</p> <input type="checkbox"/>
								<p>On</p> <input type="checkbox"/>
								<p>Off</p> <input type="checkbox"/>
								<p>On</p> <input type="checkbox"/>
								<p>Off</p> <input type="checkbox"/>
								<p>On</p> <input type="checkbox"/>
								<p>Off</p> <input type="checkbox"/>
								<p>On</p> <input type="checkbox"/>
								<p>Off</p> <input type="checkbox"/>
								<p>On</p> <input type="checkbox"/>
								<p>Off</p> <input type="checkbox"/>
								<p>On</p> <input type="checkbox"/>
								<p>Off</p> <input type="checkbox"/>
								<p>On</p> <input type="checkbox"/>
								<p>Off</p> <input type="checkbox"/>
								<p>On</p> <input type="checkbox"/>
								<p>Off</p> <input type="checkbox"/>
								<p>On</p> <input type="checkbox"/>
								<p>Off</p> <input type="checkbox"/>
								<p>On</p> <input type="checkbox"/>
								<p>Off</p> <input type="checkbox"/>
								<p>On</p> <input type="checkbox"/>
								<p>Off</p> <input type="checkbox"/>
								<p>On</p> <input type="checkbox"/>
								<p>Off</p> <input type="checkbox"/>
								<p>On</p> <input type="checkbox"/>
								<p>Off</p> <input type="checkbox"/>
								<p>On</p> <input type="checkbox"/>
								<p>Off</p> <input type="checkbox"/>
								<p>On</p> <input type="checkbox"/>
								<p>Off</p> <input type="checkbox"/>
								<p>On</p> <input type="checkbox"/>
								<p>Off</p> <input type="checkbox"/>
								<p>On</p> <input type="checkbox"/>
								<p>Off</p> <input type="checkbox"/>
								<p>On</p> <input type="checkbox"/>
								<p>Off</p> <input type="checkbox"/>
								<p>On</p> <input type="checkbox"/>
								<p>Off</p> <input type="checkbox"/>
								<p>On</p> <input type="checkbox"/>
								<p>Off</p> <input type="checkbox"/>
								<p>On</p> <input type="checkbox"/>
								<p>Off</p> <input type="checkbox"/>
								<p>On</p> <input type="checkbox"/>
								<p>Off</p> <input type="checkbox"/>
								<p>On</p> <input type="checkbox"/>
								<p>Off</p> <input type="checkbox"/>
								<p>On</p> <input type="checkbox"/>
								<p>Off</p> <input type="checkbox"/>
								<p>On</p> <input type="checkbox"/>
								<p>Off</p> <input type="checkbox"/>
								<p>On</p> <input type="checkbox"/>
								<p>Off</p> <input type="checkbox"/>
								<p>On</p> <input type="checkbox"/>
								<p>Off</p> <input type="checkbox"/>
								<p>On</p> <input type="checkbox"/>
								<p>Off</p> <input type="checkbox"/>
								<p>On</p>



Universal Card link Connection

See Wiring Insert for wire colors and which connections are used.

Pin 1. +12v- Supply to Card System = Minimum of 2A available for the card systems and a Max of 3A.

Pin 2. Coin 1 - input to the game PCB.

Pin 3. Prize Meter/Ticket Notch 2- is connected to the Ticket Notch line between the game PCB and ticket dispenser. Optional.

Pin 4. Coin Meter 1 - is connected to the coin meter 1 output from the game PCB and can be used by card systems for monitoring purposes.

Pin 5. Ticket Run/Enable 2- is connected to the ticket run line between the game PCB and ticket dispenser. Optional.

Pin 6. Prize Meter/Ticket Notch 1- is connected to the Prize or Ticket Meter output from the game PCB and can be used by card systems for monitoring purposes. Optional.

Pin 7. Coin Inhibit/Enable- is connected to the Coin or Note Inhibit/Enable output from the Game PCB and is used where the game has this feature for disabling any payment. This is normally for states like New Jersey that limit the amount of money that can be inserted at one time.

Pin 8. Ticket Run/Enable 1 - is connected to the ticket run line between the game PCB and ticket dispenser in standard redemption games. This is commonly used for systems using paperless or E-ticket. Not Used if the game doesn't have this output.

Pin 9. Ground- is connected to the common Ground connection, the same ground as the Game PCB.

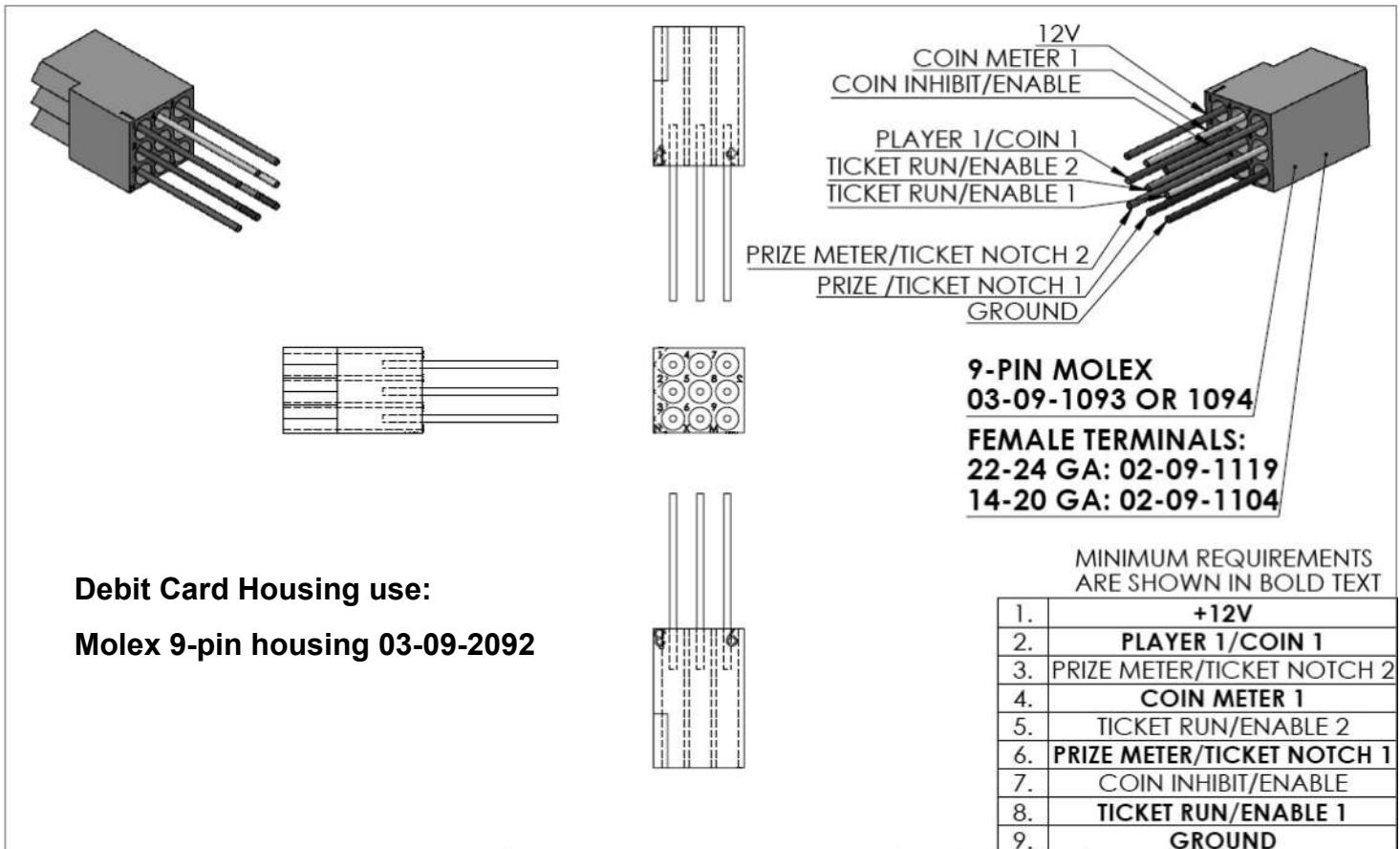

Parts Diagrams

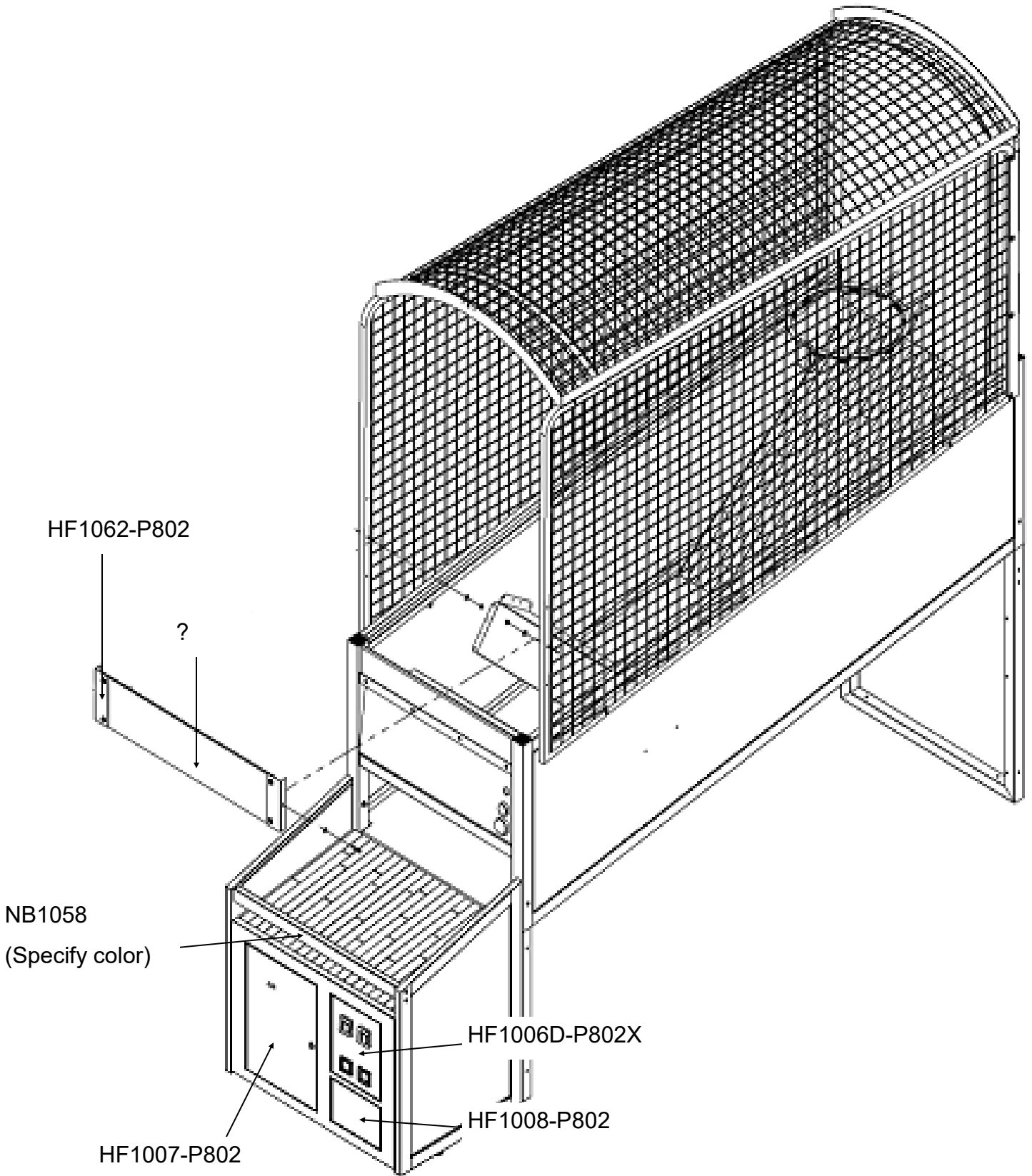

Parts Diagrams

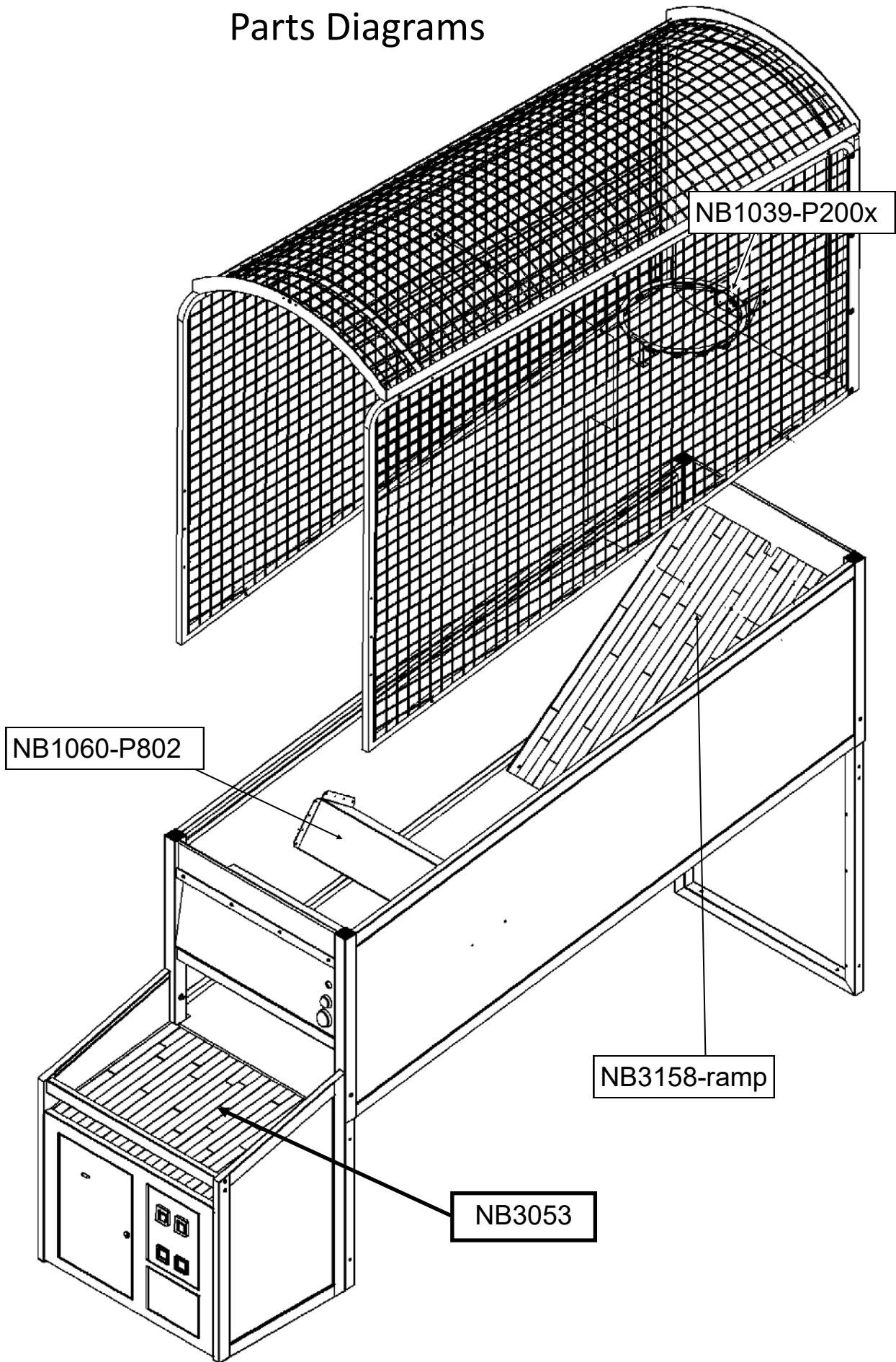

Parts Diagrams

Item #	Part Number	Description	QTY.
1	NB1060	Ball stop cover	1
2	BB1023	Ball gate motor mounting bracket	1
3	BB2008X	Ball gate motor assembly	1
4	BT1022-P802	Ball gate	1
5	BB3018	Ball gate bearing	1
6	BB3017	Ball gate bearing mounting plate	1
7	PC60603	SHCS, #10-24 x 1/2" LG	2
8	AA0655s	#8 x 3/4 SQ. drive (silver)	26
9	AA6209	1/4-20 x 1 1/4 PEM stud	2
10	AA6075	1/4 x 3/4 flat washer Zinc	2
11	PC60614	1/4-20 KEP Nut	2
12	BF1053-P802	Ball gate motor cover	1
13	PC60601	1/4-20 x 5/8 BSHCS (black)	4
14	AA6110	Joint connector 1/4-20 x 0.75 Thread	4

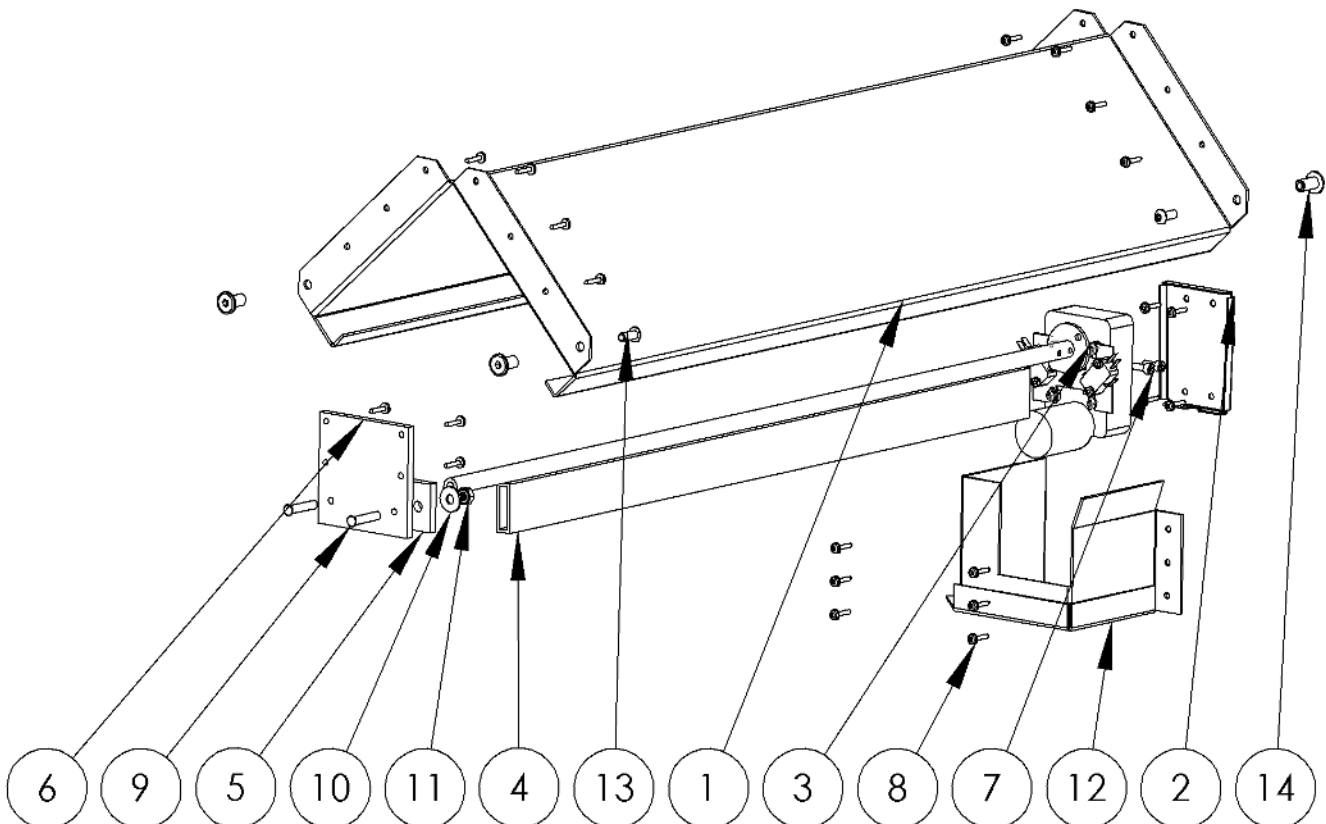

NET ASSEMBLY

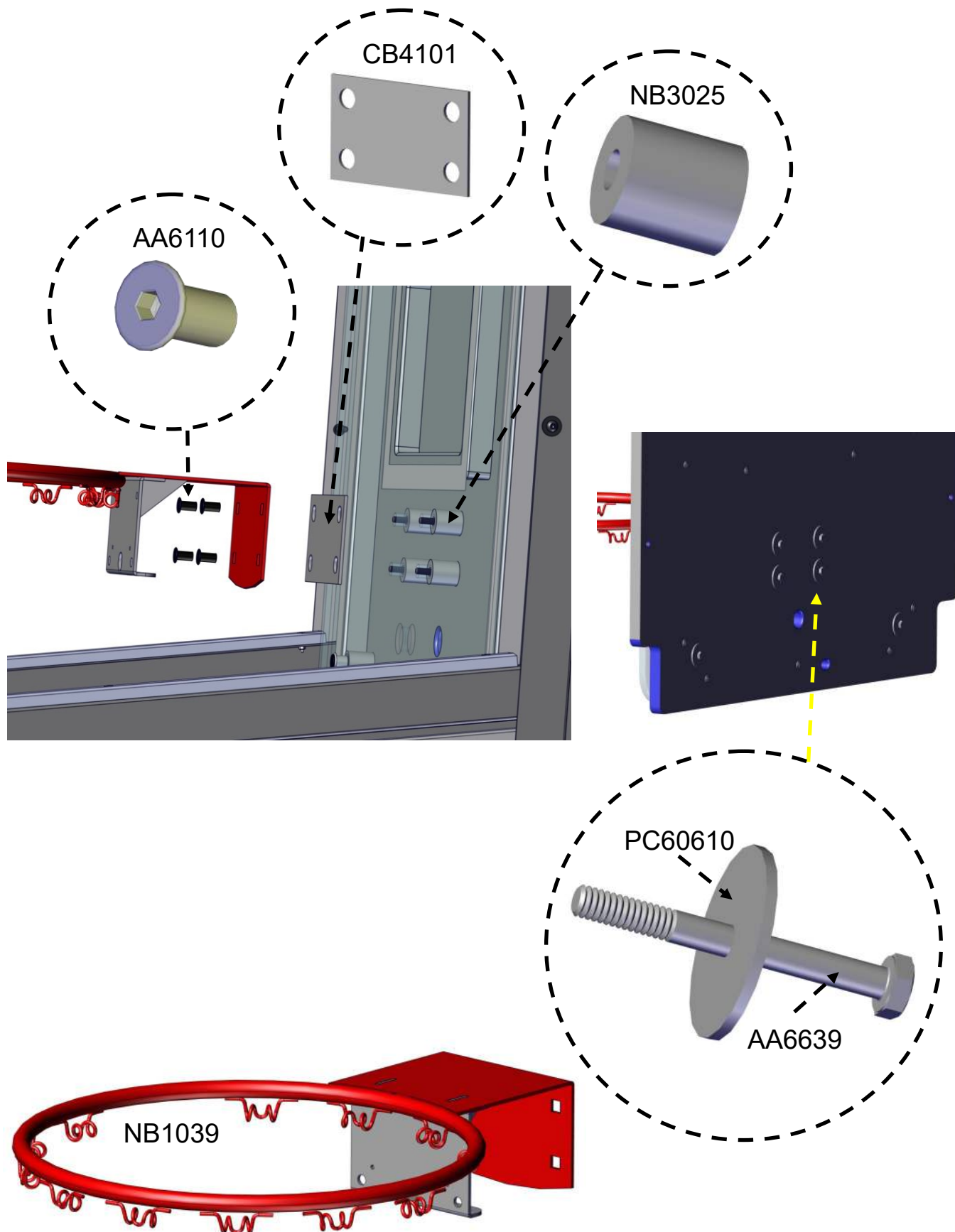

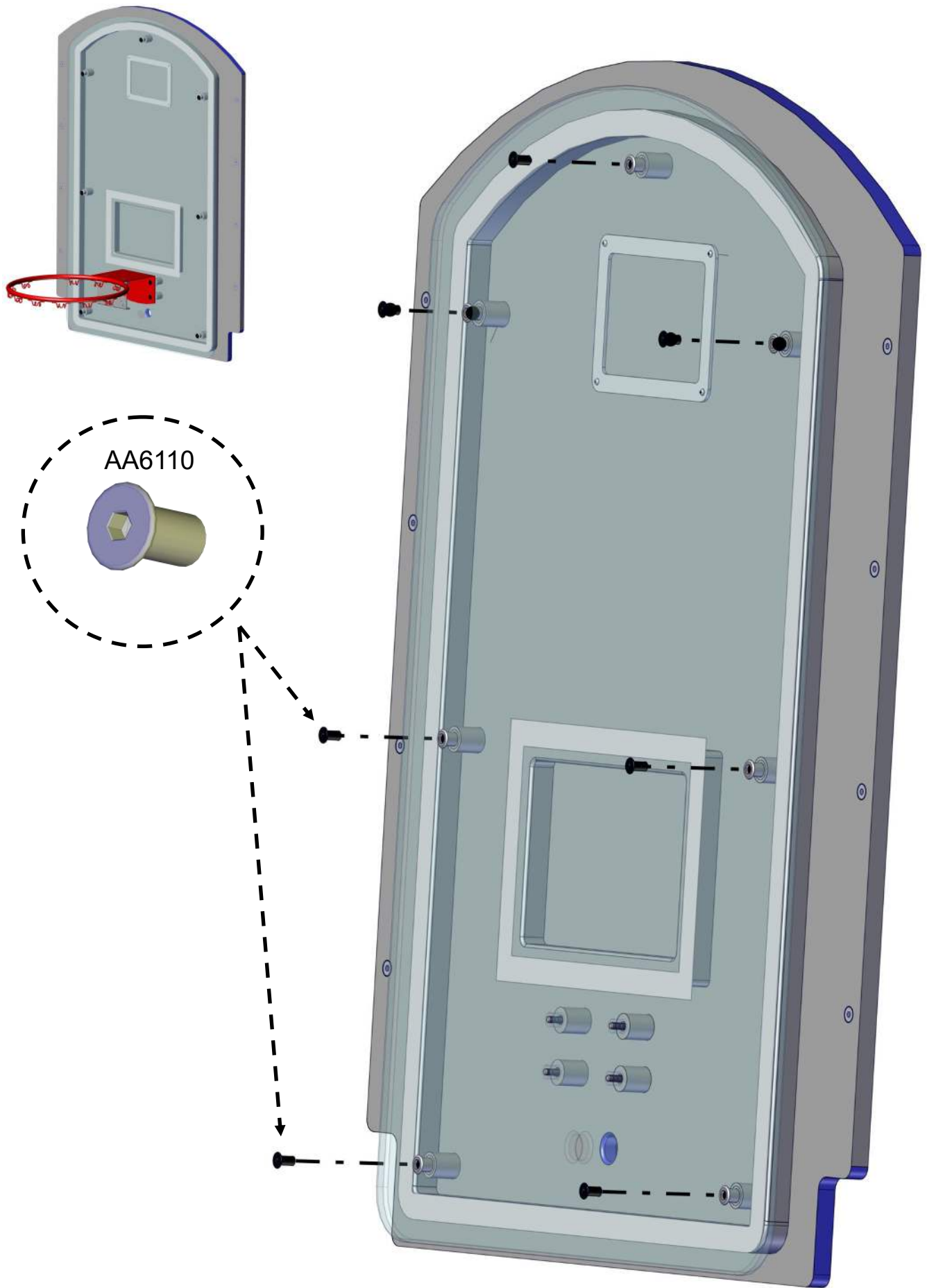

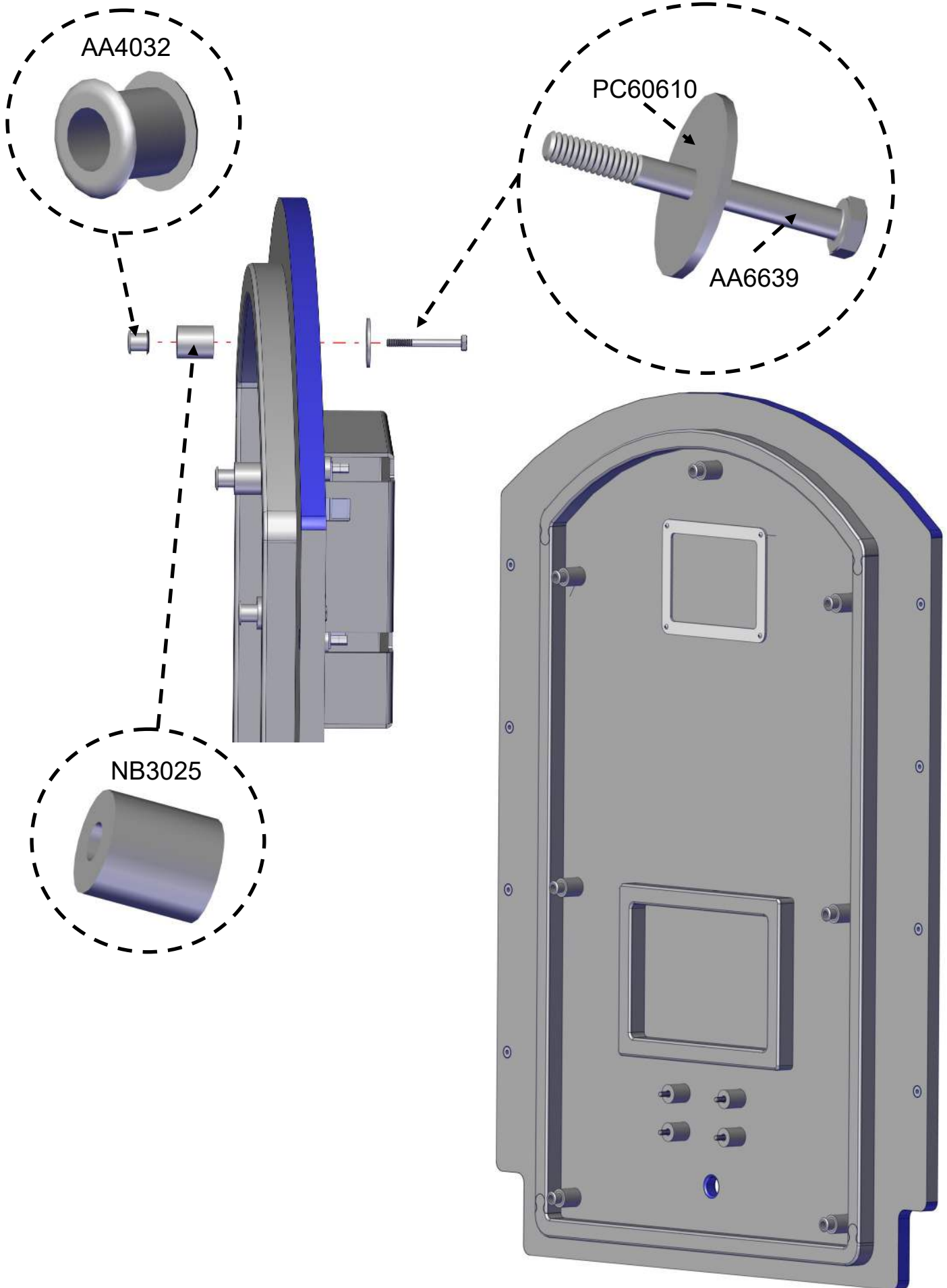



Parts Diagrams

Item No.	Part Number	Description	QTY.
1	BB2008xx	Ball Gate Motor	1
2	BB1024	Micro switch mounting bracket	1
3	BB2005	Micro switch	2
4	AA6005	8-32 x 1/4 PHMS	4
5	AA6060	4-40 x 3/4 PHMS	4
6	AA674	#4-40 Kep Nut	4

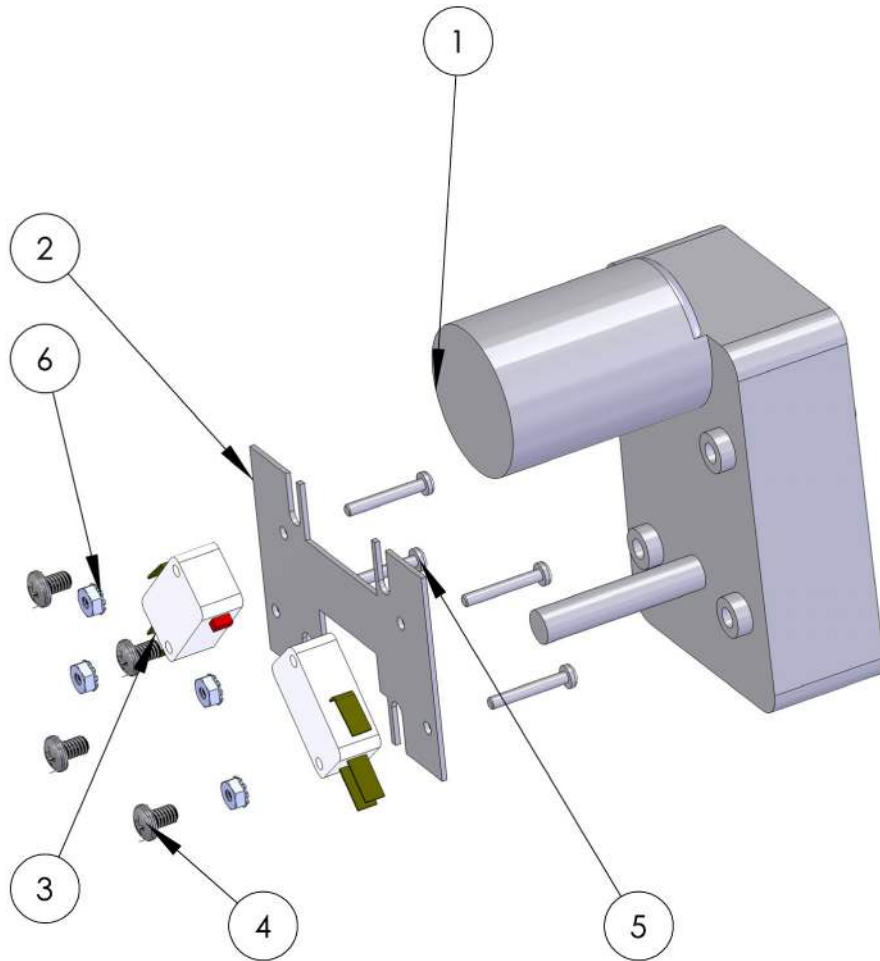

Decal Diagram

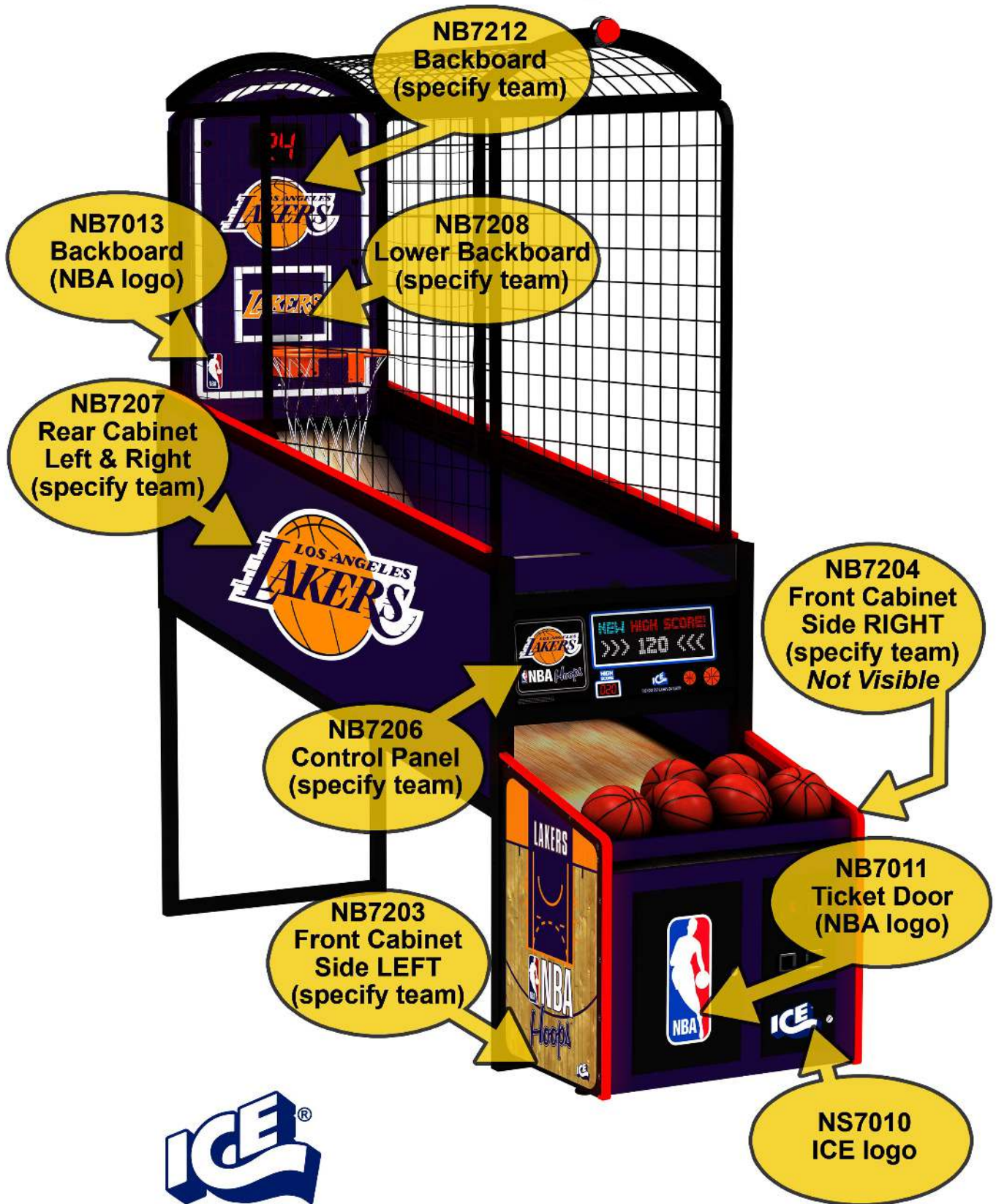

PARTS LISTINGS

MECHANICAL PARTS

GRAPHICS & DECALS

NB1005NP	Coin door panel, frame (Specify color when ordering)	HF7001	Programming decal
HF1006D-P802X	Coin door assembly	BB7004	Warning power disconnect decal
HF1007-P802	Ticket door	AA7031	"Suitable for indoor use only" decal
HF1008-P802	Cash box door	AA7032	"Caution replace fuse.....) decal
BB1009	Cash box enclosure (Galv.)	AA7033	"Warning disconnect power.....) decal
HF1016-P200	Sensor Bracket	AA7035	"On/off" decal
HF1019	Bracket (backboard side)	AA7039	"Caution hot surface" decal
NB1039-P200X	Hoop (15 inch)	AA7041	"6 amp warning" decal
HF1054-P802	Frame, red	NB7011	Decal (NBA Logo - Ticket Door)
NB1055-P802	Cage Side	NB7012	Decal (Backing Board)
NB1056-P802	Cage Top	NB7013	Decal (NBA Logo - Rear)
NB1058	Ball stop rail (Specify color)	NB9001	Service manual
NB1060-P802	Ball Deflector	NB7005	Front cab left decal
HF1062-P802	Rebound guard mtg. bracket	NB7006	Front cab right decal
HS3001	Basketball rubber	NB7010	Cash door NBA logo decal
NB3008	Basketball Net - White		Please call for team decals
BB5001	Cash box		
AA5014	Door lock		
AA6459	Allen wrench (security)		
PC60615A	#2 square drive bit		
NB3001	Basketball PVC leather hardened		
BT1022-P802	Ball gate black		



WARRANTY STATEMENT
Innovative Concepts in Entertainment
10123 Main St.
Clarence, NY 14031
Phone #: (716) - 759 - 0360
Fax #: (716) - 759 - 0884

ICE Inc warrants that all of its products will be free from defects in material and workmanship.

When placing a warranty request, please be prepared to provide the following information:

- Serial Number of Game or Bill of Sale
- Machine Type
- A Detailed Description of the Equipment Fault Symptoms

ICE product, including, Sam's Billiards, Neolith, Game Concepts & Funway is warranted as follows:

- 180 days on the Main PCB, Computers and Motors
- 1 Year on LCD/LED Monitor Panels (through Manufacturer)
- 90 days on all other electronic/mechanical components (i.e. DBV's, Ticket Dispensers)
- 30 days on all parts and repaired items

ICE Inc shall not be obligated to furnish a warranty request under the following conditions:

- Equipment has been subjected to unwarranted stress through abuse or neglect
- Equipment has been damaged as a result of arbitrary repair/modification attempts
- Equipment that has failed through normal wear and tear (bulbs, balls, buttons, etc.)

ICE Inc will assume no liability whatsoever for costs associated with labor to replace defective parts or travel time associated therein.

All defective warranty covered components will be replaced with new or factory refurbished components equal to OEM specifications. ICE Inc. (or the manufacturer) will cover domestic (U.S.A.) UPS ground (or comparable shipping means) freight costs to the customer during the warranty period. Expedited shipments are available for an additional charge at the customer's own expense.

[Defective parts are to be returned to ICE Inc. \(or the manufacturer\), at the customer's expense, in a timely fashion. They should be packaged following UPS guidelines to insure safe transit back to ICE. Adequate value freight insurance should be used in case the shipper damages the item and a claim must be filed.](#)

ICE distributors are independent, privately owned and operated. In their judgment, they may sell parts and/or accessories other than those manufactured by ICE Inc. We cannot be responsible for the quality, suitability or safety of any non-ICE part, modification (including labor) that is performed by such a distributor.